

Procedure for filing a request with IMPI regarding the Patent Prosecution Highway Pilot Program between Mexican Institute of Industrial Property (IMPI) and Intellectual Property Office of Singapore (IPOS)

The trial period of this Patent Prosecution Highway (PPH) pilot program will commence on April 14, 2017 and will end on April 14, 2020.

The trial period may be extended if necessary until IPOS and IMPI receive the sufficient number of PPH requests to adequately assess the feasibility of the PPH program.

The offices may also terminate the PPH Pilot Program if the volume of participation exceeds manageable level. Ex Ante notice will be published if the PPH Pilot Program is to be terminated.

Part I

PPH Mottainai using the national work products from IPOS

Applicants may request accelerated examination by a prescribed procedure including submission of relevant documents on an application which is filed with IMPI and satisfies the following requirements under the IPOS-IMPI PPH Pilot Program.

When a request for participation in the PPH Pilot Program is presented, the applicant must file a free style writing IMPI. (See section 3)

1. Requirements

- (a) The application at the IMPI in which PPH is request and the application (s) of the Office of Earlier Examination (OEE, in this case IPOS) that forms the basis of the PPH request will be corresponding patent applications. The IMPI application for which participation in the PPH is requested and the corresponding OEE application must have the same earliest date (whether this is a priority date or a filing date), wherein the IMPI application (including an application PCT national phase) is either:**
- (i) an application which validly claims priority under the Paris Convention to IPOS application(s) (examples are provided in Annex I, examples A, B, C, and D), or
 - (ii) an application which is the basis of a valid priority claim under the Paris Convention for the IPOS application(s) (including PCT national phase application(s)) (See ANNEX I, examples E, F and G), or
 - (iii) an application which shares a common priority document with the IPOS application(s) (including PCT national phase application (s)) (See Annex I, examples H, H1, I, J, K, L), or
 - (iv) a PCT national phase application where both the IMPI application and the IPOS application(s) are derived from a common PCT application having no priority claim (See ANNEX I, example M).

The term "corresponding patent applications" should not necessarily be interpreted as the application which forms the basis of the priority, but might be the application which derived from the application which forms the basis of the priority or the PCT application which has no priority claim, for example, a divisional application of the application or an application claiming national priority to the application which forms

the basis of priority.

(b) At least one corresponding application in IPOS has one or more claims that are determined to be patentable/allowable by IPOS.

Applicant should identify the relationship between the IPOS application containing patentable/allowable claims and IMPI application.

Claims are considered patentable/allowable, when the IPOS examiner clearly identifies the claims as patentable/allowable in the latest office action by the office, even if the application is not granted for a patent yet.

Office actions are:

- Written Opinions
- Search and Examination Reports
- Examination Reports

Claims are also considered as patentable/allowable in the following situation: If the IPOS office action does not explicitly state that a particular claim is patentable/allowable, the applicant must include an explanation accompanying the request for participation in the PPH Pilot Program containing technical analysis of that claim with respect to the prior art cited, indicating that there was no objection from the IPOS regarding that claim, and therefore, the claim is deemed patentable/allowable by IPOS.

(c) All claims in the IMPI application (for which an accelerated examination under the PPH Pilot Program is requested), as originally filed or as amended, must sufficiently correspond to one or more claims determined to be patentable/allowable in IPOS.

Claims are considered to “sufficiently correspond” where, accounting for differences due to translations and claim format, the claims in IMPI are of the same or similar scope as the claims in IPOS, or the claims in IMPI are narrower in scope than the claims in IPOS. For example, a claim that is narrower in scope occurs when a IPOS claim is amended to be further limited by an additional technical feature that is supported by the originally filed specification at IMPI (description and/or claims).

A claim of IMPI which introduces a new/different category of claims to those claims determined to be patentable/allowable in IPOS is not considered to sufficiently correspond. For example, if IPOS claims only contain claims to a process of manufacturing a product, then the claims in IMPI are not considered to sufficiently correspond if IMPI claims introduce product claims that are dependent on the corresponding process claims.

It is not required to include “all” claims determined to be patentable/allowable by IPOS (the deletion of claims is allowable). For example, in the case where an application in IPOS contains 5 claims determined to be patentable/allowable, the application in IMPI may contain only 3 of these 5 claims.

Refer to ANNEX III for the cases which are considered to “sufficiently correspond” and

the cases which are not considered to “sufficiently correspond”.

Any claims amended or added after the submission of the request for participation in the PPH pilot program but before the first IMPI action must sufficiently correspond to the claims indicated as patentable/allowable in the IPOS application. Any claims amended or added after the first IMPI action need not to sufficiently correspond to the claims indicated as patentable/allowable in IPOS in order to overcome the reasons for refusal raised by IMPI examiner.

(d) The IMPI application must have been published.

The publication in the Gazette must have taken effect, and the time period of six months provided in Article 52 bis of the Mexican Industrial Property Law (LPI) to receive comments from third parties must have ended.

(e) IMPI has not begun the substantive examination of the patent application at the time of request for participation in the PPH Pilot Program (the example is provided in ANNEX I, Figure N).

2. Documents to be submitted

Documents (a) to (d) below must be submitted by attaching them to the PPH request.

Note that even when it is not required to submit some of the documents below, the name of such documents must be listed on the request for participation in the PPH Pilot Program (Please refer to the example of free style writing below for details).

(a) Copies of all official actions (which are relevant to determining patentability in IPOS), which were issued for the corresponding IPOS application and its translations.

(b) Copies of all claims determined to be patentable/allowable by IPOS and its translations.

(c) Copies of references cited by the IPOS examiner.

The documents to be submitted are those cited in the above-mentioned office actions. Documents which are only referred to as references and consequently do not consist of the reasons for refusal do not have to be submitted.

If the references are patent documents, the applicant does not have to submit them because IMPI usually possesses them. When the patent document is not available to the IMPI examiner the applicant must submit the patent document at the examiner's request.

Non-patent literature must always be submitted.

The translations of the references are unnecessary.

(d) Claim correspondence table.

The PPH applicant must submit a claim correspondence table, which indicates how all claims in the IMPI application sufficiently correspond to the patentable/allowable claims in the IPOS application.

When claims are just literal translation, the applicant can just write down that “they are the same” in the table. When claims are not just literal translation, it is necessary to explain the sufficient correspondence of each claim based on the criteria 1.(c) (Please refer to the example of the free style writing below).

For avoidance of doubt, a copy of the patent grant without the documents listed in 2 (a), (b) and (d) above will not qualify for the PPH.

3. Request for accelerated examination under the PPH Pilot Program

(a) Circumstances:

When an applicant files a request for participation in the PPH Pilot Program with IMPI, the applicant must submit a free style writing explaining the circumstances for its participation, according to the guidelines described in this document.

The applicant must indicate that the application belongs to any of the categories (i) to (iv) of 1.(a), and that the accelerated examination is requested under the PPH pilot program. The application number, publication number or patent number of the corresponding IPOS application must be written as well.

In the case where a IPOS application, which has one or more claims that are determined to be patentable/allowable does not directly belong to any of the categories (i) to (iv) of 1.(a) (for example, the divisional application of the basic application that belongs to any of the categories (i) to (iv) of 1.(a)), the application number, publication number, or correspondent patent of the IPOS application which has claims determined to be patentable/allowable and the relationship between those applications must be written down.

(b) Documents to be submitted:

The applicant must list all required documents mentioned in section 2, on an identifiable way, even when the applicant is exempted to submit certain documents.

(c) Sample of free style writing (Español)

Lugar y Fecha
Asunto: Petición para participar en el Programa Piloto PPH IMPI-IPOS
Número de solicitud ante el IMPI
Fecha de presentación
Título de la invención
Solicitante
Apoderado, representante legal o mandatario
Domicilio para oír y recibir notificaciones

Instituto Mexicano de la Propiedad Industrial
Dirección Divisional de Patentes
PRESENTE

Por este conducto, se solicita la inclusión de la solicitud de patente con número de expediente MX/a/XXXX/XXXXXX dentro del Programa Piloto del PPH IMPI-IPOS, correspondiente a la solicitud de patente SG XXXXXX presentada ante IPOS y que cumple con la relación prevista en el inciso (X) del punto 1.(a) (*Explique la razón por la que cumple con esa relación*).

Para efecto de lo anterior, se enlistan los documentos que se anexan y los que no se anexan por ser documentos de patente.

- (a) Copia de todas las acciones oficiales que fueron relevantes para determinar la patentabilidad de la solicitud de patente en IPOS, que fueron emitidas para la solicitud correspondiente en IPOS y, en su caso, su traducción; a saber:
 - 1. Acción oficial 1
 - 2. ...

- (b) Copia de todas las reivindicaciones que han sido indicadas como patentables/otorgables por la IPOS y, en su caso, su traducción:
 - 1. Las reivindicaciones patentables/otorgables son las originalmente presentadas ante la IPOS.

- (c) Copia de todas las referencias citadas por el examinador de la IPOS:
 - 1. SG XXXXX (no se anexa por ser documento de patente)
 - 2. US
 - 3. EP ... etc.

- (d) Tabla de correspondencia de reivindicaciones:

Tabla de correspondencia de reivindicaciones		
Reivindicaciones en la solicitud en el IMPI	Reivindicaciones patentables/otorgables en la solicitud en IPOS	Explicación sobre la suficiente correspondencia
XXX	XXX	Son lo mismo
YYY	XYZ	Justificación de la suficiente correspondencia
...

Nombre y firma del solicitante o apoderado.

(d) Sample of free style writing (English)

Place and Date
Subject: Request of participation in the PPH Pilot Program IMPI-IPOS
Application number before IMPI
Filing Date
Title of the Invention:
Applicant
Attorney or legal representative

Mexican Institute of Industrial Property
Patent Division

Through this means, we request the inclusion of the application with file number MX/a/XXXX/XXXXXX into the PPH Pilot Program IMPI-IPOS, corresponding to the application SG XXXXXX filed before the IPOS and which has met the conditions provided in subsection (X) of paragraph 1.(a) (*Explain the reasons why it complies with these conditions*) and, for this purpose, we attach a list of the following documents:

- (a) Copy of all IPOS Office Actions which were relevant to patentability in the above-identified IPOS application(s) (and where appropriate, their translation).
 - 1. Office Action 1
 - 2. ...
- (b) Copy of all claims which were determined to be patentable/allowable by IPOS in the above-identified IPOS application(s) (and where appropriate, their translation).
 - 1. The claims as originally filed and determined patentable/allowable by IPOS.
- (c) References cited by IPOS, not annexed, as they are patent documents.
 - 1. SG XXXXX
 - 2. US
 - 3. EP ... etc.
- (d) Claims correspondence Table

Claims in the MX application	Claims in the IPOS application	Explanation regarding the sufficient correspondence
XXX	XXX	They are the same
XYY	XYZ	Justification of sufficient correspondence
...

Name and signature of applicant or patent attorney

4. Procedure for the accelerated examination under the PPH Pilot Program

When the request for participation in the PPH pilot program comply with all the above requirements, it will be accepted and IMPI patent application may be advanced out of turn for examination, provided it complies with the publication established in Article 52 of the LPI and upon expiration of the period for third parties observations referred to in Article 52 bis of the LPI.

If the PPH request is filed before the expiration of the time period indicated above, IMPI shall determine whether the patent application may be entitled for accelerated examination under the PPH until this period ends.

In those instances where the request for participation in the PPH pilot program is not accepted because it does not meet all the above requirements, the applicant will be notified and the defects in the request will be identified. The applicant may resubmit the request up to one more time with the specified defects corrected.

If the second request submitted is not accepted, the applicant will be notified and the patent application will await its normal turn for examination.

IMPI will not notify the applicant of the acceptance for assigning a special status for accelerated examination under the PPH, but instead the applicant will be aware by the reception of an office action of substantive examination procedure resulting from accelerated examination.

Applications for utility models and industrial designs, as well as claims of patent applications containing material considered not patentable in accordance with Articles 4, 16 and 19 of the LPI are not subject to participation in the PPH pilot program.

The acceptance of a participation request in the PPH pilot program in a parent application will not carry over to a divisional application. The applicant must submit a new request of participation in the PPH pilot program for the divisional application and fulfill all the conditions set forth above in order to be accepted.

If any of the documents identified in 2 (a) to 2 (d) above has already been filed in the IMPI application, prior to the request for participation in the PPH pilot program, it will not be necessary for the applicant to resubmit these documents with the request for participation. The applicant may simply refer to these documents and indicate in the request for participation in the PPH pilot program when these documents were previously filed in the IMPI application.

All the correspondence concerning the accelerated examination procedure is presented at the IMPI, must be clearly identified as relating to a PPH request to ensure that the correspondence is correctly processed. For these purposes, please prominently mark each page of the covering letter of the correspondence with the term "PPH".

It is recommended that when requesting accelerated examination under the PPH, applicants should not only focus on the claims, but on the application as a whole. The applicant should review the complete application and make the necessary amendments to be consistent with all the information in the application, without adding new matter to the originally filed application.

It is noted that all the amendments made to the application in order to be examined under the PPH will be entered regardless of whether the request for participation in the PPH pilot program is accepted or not.

The PPH program does not absolve applicants of all their duties under the Mexican Industrial Property Law and applicable legislation. Applicants must act in good faith, including the submission of information known by them to IMPI, which is relevant to determine the patentability of the invention.

Part II
PPH using the PCT international work products from IPOS

Applicants may request accelerated examination by a prescribed procedure including submission of relevant documents on a patent application which is filed with IMPI and satisfies the following requirements under the IMPI-IPOS Patent Prosecution Highway pilot program based on PCT international work products (PCT pilot PCT-PPH).

When filing a request for the PCT-PPH pilot program, an applicant must submit a free style writing at the IMPI. (See section 3).

1. Requirements

The patent application is filed with the IMPI and in which the applicant files a request under the PCT-PPH must satisfy the following requirements:

- (a) The latest work product in the international phase of a PCT application corresponding to the application (“international work product”), namely the Written Opinion of International Search Authority (WO/ISA), the Written Opinion of International Preliminary Examination Authority (WO/IPEA) or the International Preliminary Examination Report (IPER), indicates at least one claim as patentable/allowable (from the aspect of novelty, inventive steps and industrial applicability).**

Note that the ISA and the IPEA which produced the WO/ISA, WO/IPEA and the IPER are limited to IPOS, but, if priority is claimed, the priority claim can refer to an application in any Office, see example A' in ANNEX II (ZZ application can be any national application).

The applicant cannot file a request under PCT-PPH on the basis of an International Search Report (ISR) only.

In case any observation is described in Box VIII of WO/ISA, WO/IPEA or IPER which forms the basis of a PCT-PPH request, the applicant must explain why the claim(s) is/are not subject to the observation irrespective of whether or not an amendment is submitted to correct the observation noted in Box VIII. The application will not be eligible for participating in PCT-PPH Pilot Program if the applicant does not explain why the claim(s) is/are not subject to the observation. In this regard, however, this does not affect the decision on the eligibility of the application whether the explanation is adequate and/or whether the amendment submitted overcomes the observation noted in Box VIII.

- (b) The relationship between the IMPI application and the corresponding international application satisfies one of the following requirements:**

- i. The application is a national phase application of the corresponding international application. (See Figures A, A', and A'' in ANNEX II)
- ii. The application is a national application as a basis of the priority claim of the corresponding international application. (See Figure B in ANNEX II)
- iii. The application is a national phase application of an international application claiming priority from the corresponding international application. (See Figure C in

ANNEX II)

- iv. The application is a national application claiming foreign/domestic priority from the corresponding international application. (See Figure D in ANNEX II)
- v. The application is the derivative application (divisional application and application claiming domestic priority, etc.) of the application which satisfies one of the above requirements (i) – (iv). (See Figures E1, E2 and E3 in ANNEX II)

(c) All claims on file as originally filed or as amended, for examination under the PCT-PPH must sufficiently correspond to one or more of those claims indicated to be patentable/allowable in the latest international work product of corresponding international application.

Claims are considered to "sufficiently correspond" when, considering the differences arising from the translation and/or claims format, the claims of the application are of the same or similar scope as the claims indicated as patentable/granted in the latest international work product or the claims of the application are narrower in scope than the claims in the latest international work product.

In this regard, a claim that is narrower claim occurs when indicated as patentable/allowable in the product of the latest international work is modified to be even more limited by additional technical feature is supported in the specification (description and/or claims) originally filed at the IMPI.

A claim of the application at the IMPI, that introduces a new/different category of claims to those claims indicated as patentable/allowable in the latest international work product is not considered to sufficiently correspond. For example, the claims indicated as patentable/allowable in the latest international work product only contain claims to a process of manufacturing a product, therefore the claims of the application presented before IMPI are not considered to sufficiently correspond if the claims of the application introduce product claims that are dependent on the corresponding process claims.

It is not required to include "all" claims determined to be patentable/allowable in the product of the latest international work (the deletion of claims is allowable). For example, in the case where an international application contains 5 claims identified as patentable/allowable, the application at the IMPI may contain only 3 of these 5 claims.

Refer to ANNEX III for the cases which are considered to "sufficiently correspond" and the cases which are not considered to "sufficiently correspond".

Any claims amended or added after the submission of the request for participation in the PCT-PPH Pilot Program but before the first IMPI action must sufficiently correspond to the claims indicated as patentable/allowable in the latest international work product. Any claims amended or added after the first IMPI action need not sufficiently correspond to the claims indicated as patentable/allowable in the latest international work product in order to overcome the reasons for refusal raised by IMPI examiner.

(d) The IMPI application must have been published.

The publication in the Gazette must have taken effect, and the time period of six months provided for in Article 52 bis of the LPI to receive comments from third parties must have ended.

- (e) IMPI has not begun the substantive examination of the patent application at the time of request under PCT-PPH (See Figure F in ANNEX II).**

2. Documents to be submitted

Documents (a) to (d) below must be submitted by attaching them to the PCT-PPH.

Note that even when it is not required to submit some of the documents below, the name of the documents must be listed in the request for participation in the PCT-PPH pilot program (Please refer to the example of free style writing below for detail).

- (a) A copy of the latest international work product which indicates the claims to be patentable/allowable and its translations.**

If the application satisfies the relation 1. (b) (i), the applicant does not need to submit a copy of the latest international work product or its translation because normally a copy of this document is already contained in the file-wrapper of the application or is available via "PATENTSCOPE ®", unless is required by the IMPI.

(WO/ISA and IPER are usually available as "IPRP Chapter I" and "IPRP Chapter II" respectively in 30 months after the priority date.)

- (b) A copy of a set of claims which the latest international work product of the corresponding international application indicated to be patentable/allowable and its translations.**

If the copy of the set of claims indicated as patentable/allowable is available via "PATENTSCOPE ®" (for example, the international Patent Gazette has been published), the applicant need not submit this document unless otherwise required by the IMPI.

- (c) A copy of references cited in the latest international work product of the international application corresponding to the application.**

Documents which are only referred to as reference and therefore do not provide reasons for refusal do not have to be submitted.

If the references are patent documents, the applicant does not submit them because the IMPI examiner usually can get them. When a patent document is not available to the IMPI examiner, it may be requested to the applicant.

Non-patent literature must always be submitted.

The translations of cited references are unnecessary.

- (d) A claims correspondence table which indicates how all claims of the IMPI**

application sufficiently correspond to the claims indicated as patentable/allowable in the latest international work product.

When claims are just literal translation, the applicant can write down that “they are the same” in the table. When claims are not just literal translation, it is necessary to explain the sufficient correspondence of each claim based on the criteria 1. (c) (Please refer to the Example of the free style writing below).

3. Request for accelerated examination under the PCT-PPH pilot program.

(a) Circumstances:

When an applicant submits a request to participate in the program the PCT-PPH pilot with the IMPI, must submit a free styling writing explaining the circumstances for its participation, according to the guidelines described in this document.

The applicant must indicate that the application belongs to any of the categories (i) to (v) of section 1 (b), and that the accelerated examination is requested under the PCT-PPH pilot program. The international application number or international publication number must be indicated as well.

In the case that the international application has one or more claims that are determined to be patentable/allowable does not directly belong to any of the categories of subparagraphs (i) to (v) of section 1. (b) (for example, a divisional application of the basic application that belongs to any category of subparagraphs (i) to (v) of section 1. (b)), the international application number or international publication number of the international application which has claims determined to be patentable/allowable and the relationship between those applications must be indicated.

(b) Documents to be submitted:

The applicant must list all required documents mentioned in section 2, on an identifiable way, even when the applicant is exempted to submit certain documents.

(c) Sample of free style writing (Spanish)

Lugar y Fecha
Asunto: Petición para participar en el Programa Piloto PCT-PPH IMPI-IPOS
Número de solicitud ante el IMPI
Fecha de presentación
Título de la invención
Solicitante
Apoderado, representante legal o mandatario
Domicilio para oír y recibir notificaciones

Instituto Mexicano de la Propiedad Industrial
Dirección Divisional de Patentes
PRESENTE

Por este conducto, se solicita la inclusión de la solicitud de patente con número de expediente MX/a/XXXX/XXXXXXXX en el Programa Piloto del PCT-PPH IMPI-IPOS, correspondiente a la solicitud internacional XXXXXX y que cumple con la relación prevista en el inciso (X) del punto 1 (b) (*Explique la razón por la que cumple con esa relación*).

Para efectos de lo anterior se enlistan los documentos que se anexan y los que no se anexan por estar disponibles a través del sistema PATENTSCOPE ® o ser documentos de patente.

- (a) Copia del último resultado de la fase internacional que indica las reivindicaciones que son patentables/otorgables y, en su caso, su traducción. (No se anexa por estar disponible en PATENTSCOPE)
- (b) Copia del capítulo reivindicatorio que de acuerdo con el último resultado de la fase internacional de la solicitud PCT correspondiente se indica como patentable/otorgable y, en su caso, su traducción. . (No se anexa por estar disponible en PATENTSCOPE)
- (c) Copia de las referencias citadas en el último resultado de la fase internacional de la solicitud PCT correspondiente a la solicitud.
- (d) Tabla de correspondencia de reivindicaciones:

Tabla de correspondencia de reivindicaciones		
Reivindicaciones en la solicitud en el IMPI	Reivindicaciones otorgables/patentables en la solicitud internacional	Explicación sobre la suficiente correspondencia
XXX	XXX	Son lo mismo
YYY	XYZ	Justificación de la suficiente correspondencia
...

Nombre y firma del solicitante o apoderado.

(d) Sample of free style writing (English)

Place and Date
Subject: Request of participation in the PCT-PPH Pilot Program IMPI-IPOS
Application number before IMPI
Filing Date
Title of the Invention:
Applicant
Attorney or legal representative

Mexican Institute of Industrial Property
Patent Division

Through this means, we request the inclusion of the application with file number MX/a/XXXX/XXXXXX/ into the PCT-PPH Pilot Program IMPI-IPOS corresponding to the international application XXXXXX and which has met the conditions provided in subsection (X) of paragraph 1 (b) (*Explain the reasons why it complies with these conditions*). For this purpose, we attach a list of the following documents (submission of such documents is omitted because they are available in the PATENTSCOPE®):

- (a) Copy of the latest international work product which determines the patentability/allowability of some claims in the above identified international application(s) and where appropriate, its translation. (not annexed, as it is available in PATENTSCOPE®)
- (b) Copy of all claims which were determined to be patentable/allowable by the latest international work product in the above identified International application(s) and where appropriate, its translation. (not annexed, as it is available in PATENTSCOPE®)
- (c) References cited by IPOS, in the latest international work product in the above identified International application(s), not annexed as they are patent documents.
- (d) Claims correspondence Table

Claims correspondence table		
Claims in the MX application	Claims patentable/allowable in the international application	Explanation regarding the sufficient correspondence
XXX	XXX	They are the same
XYX	XYZ	Justification of sufficient correspondence

Name and signature of applicant or patent attorney

4. Procedure for the accelerated examination under the PCT-PPH Pilot Program

When the request for participation in the PCT-PPH pilot program comply with all the above requirements, it will be accepted and IMPI patent application may be advanced out of turn for examination, provided it complies with the publication established in Article 52 of the LPI and upon expiration of the period for third parties observations referred to in Article 52 bis of the LPI.

If the PCT-PPH request is filed before the expiration of the time period indicated above, IMPI shall determine whether the patent application may be entitled for accelerated examination under the PCT-PPH until this period ends.

In those cases where the request for participation in the PCT-PPH pilot program is not accepted because it does not meet all the above requirements, the applicant will be notified and the defects in the request will be identified. The applicant may resubmit the request up one more time with the specified defects corrected.

If the second request submitted is not accepted, the applicant will be notified and the patent application will await its normal turn for examination.

IMPI will not notify the applicant of the acceptance for assigning a special status for accelerated examination under the PCT-PPH, but instead the applicant will be aware by the reception of an office action of substantive examination procedure resulting from accelerated examination.

Applications for utility models and industrial designs, as well as claims of patent applications containing material considered not patentable in accordance with Articles 4, 16 and 19 of the LPI are not subject to participation in the PCT-PPH pilot program.

The acceptance of a participation request in the PCT-PPH pilot program in a parent application will not carry over to a divisional application. The applicant must submit a new request of participation in the PCT-PPH Pilot Program for the divisional application and fulfill all the conditions set forth above in order to be accepted.

If any of the documents identified in 2 (a) to 2 (d) above has already been filed in the IMPI application, prior to the request for participation in the PTC-PPH pilot program, it will not be necessary for the applicant to resubmit these documents with the request for participation. The applicant may simply refer to these documents and indicate in the request for participation in the PCT-PPH pilot program when these documents were previously filed in the IMPI application.

All the correspondence concerning the accelerated examination procedure is presented at the IMPI, must be clearly identified as relating to a PCT-PPH request to ensure that the correspondence is correctly processed. For these purposes, please prominently mark each page of the covering letter of the correspondence the term "PPH".

It is recommended that when requesting accelerated examination under the PCT-PPH, applicants should not only focus on the claims, but on the application as a whole. The applicant should review the complete application and make the necessary amendments to be consistent with all the information in the application, without adding new matter to the originally filed application.

It is noted that all the amendments made to the application in order to be examined under the PCT-PPH will be entered regardless of whether the request for participation in the PCT-PPH pilot program is accepted or not.

The PCT-PPH program does not absolve applicants of all their duties under the Mexican Industrial Property Law and applicable legislation. Applicants must act in good faith, including the submission of information known by them to IMPI, which is relevant to determine the patentability of the invention.

ANNEX I

Examples of Mexican patent applications that may request the accelerated examination under the PPH before IMPI:

OEE is Office of Earlier Examination, in this case refers to IPOS

ZZ is any office

DO is Designated Office

Example A:

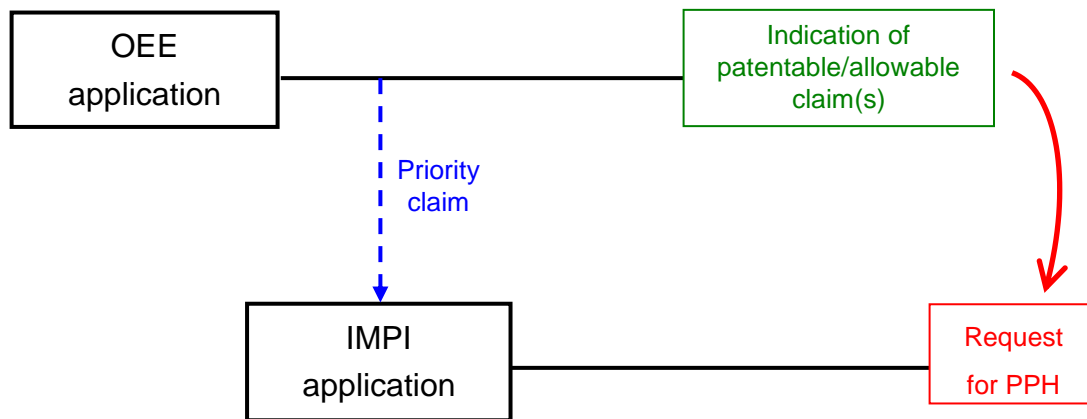

Example B:

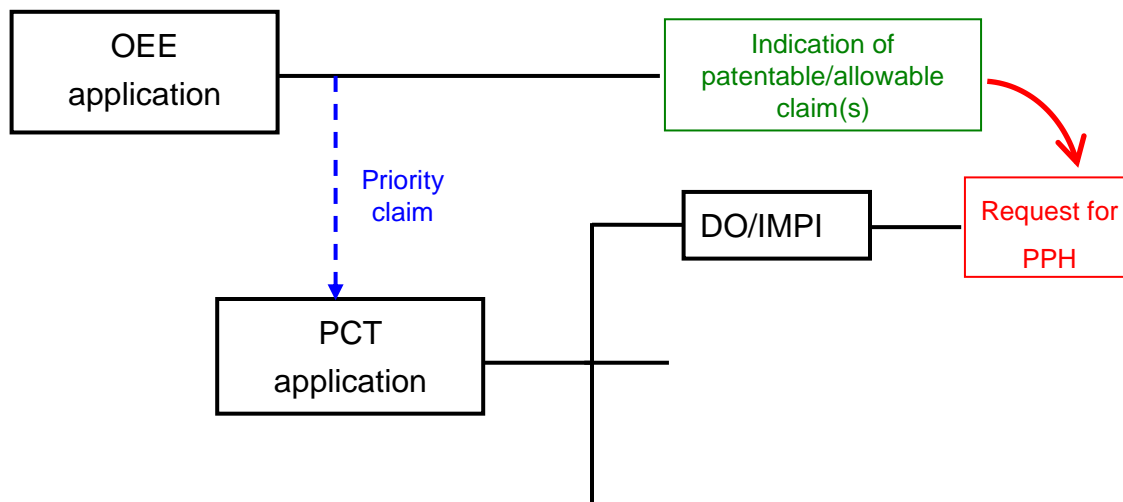

Example C:

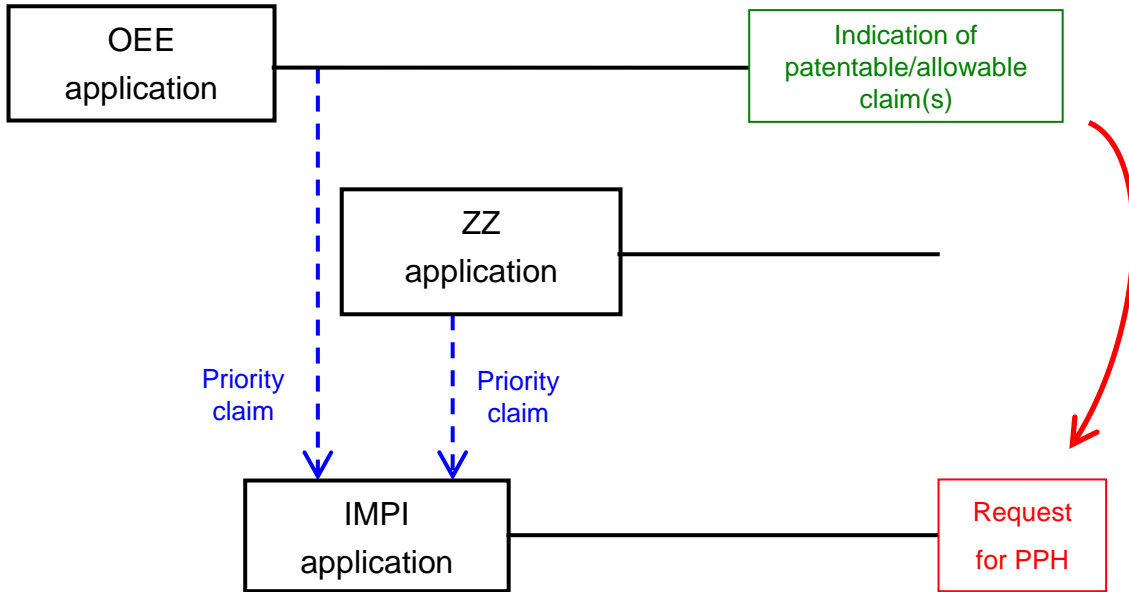

Example D:

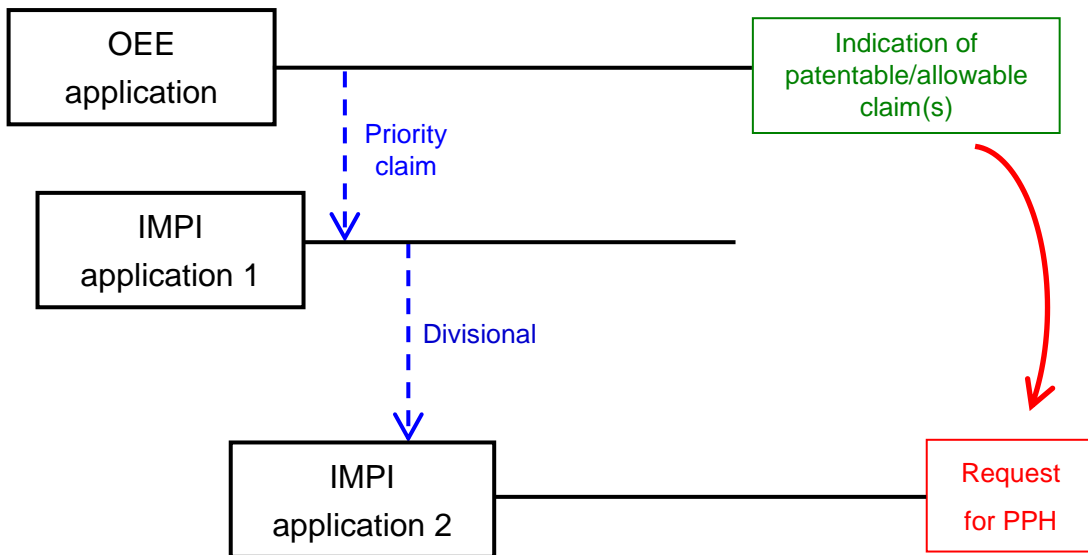

Example E:

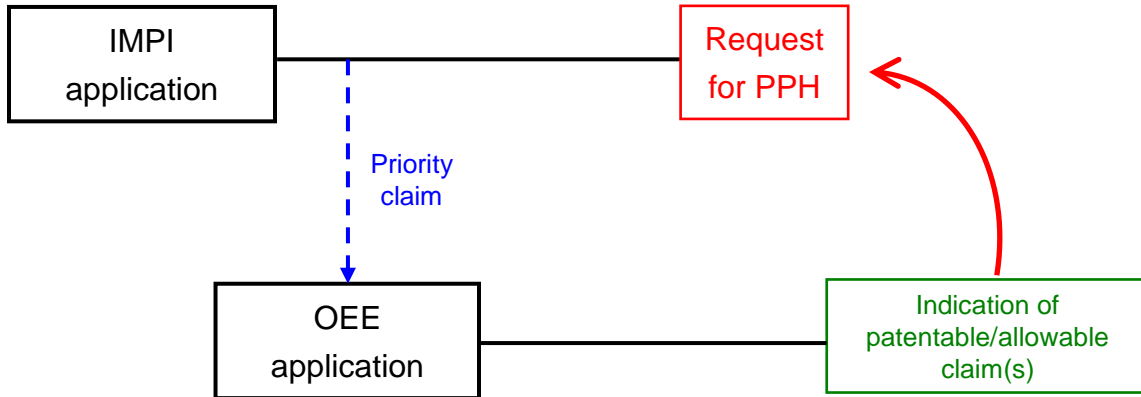

Example F:

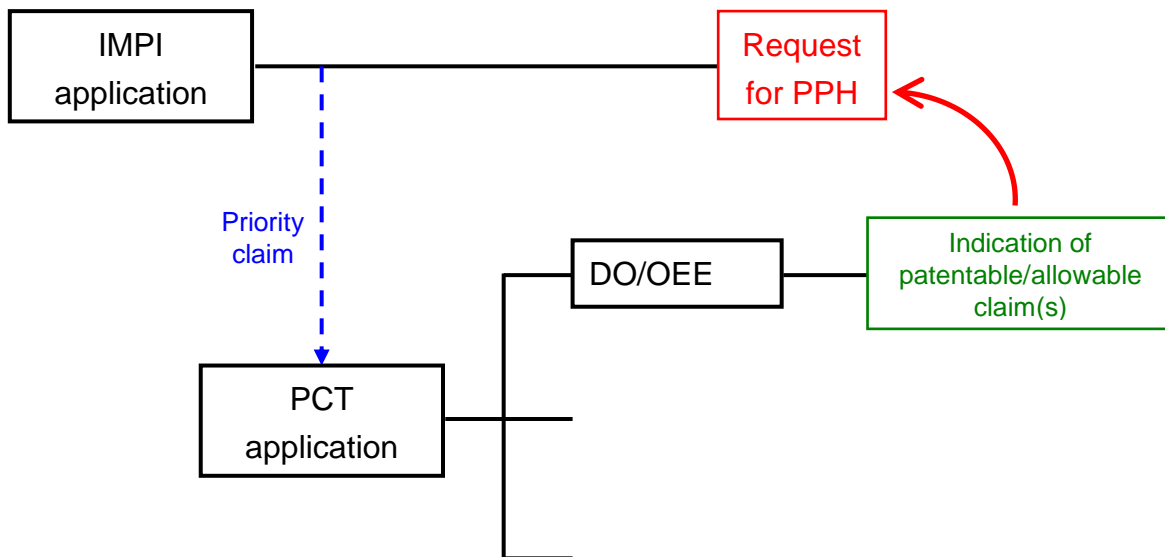

Example G:

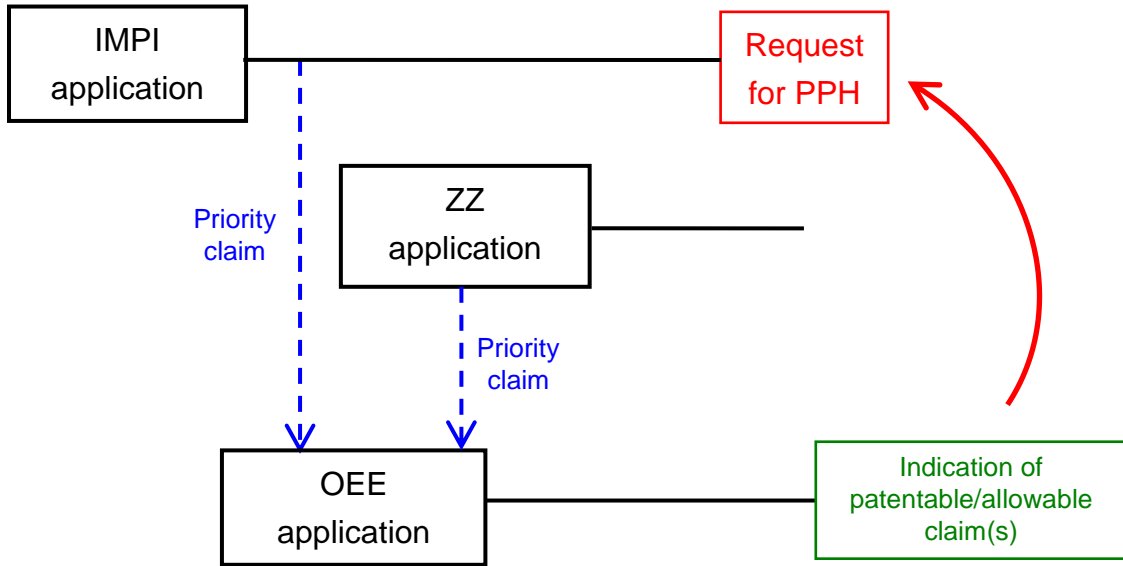

Example H:

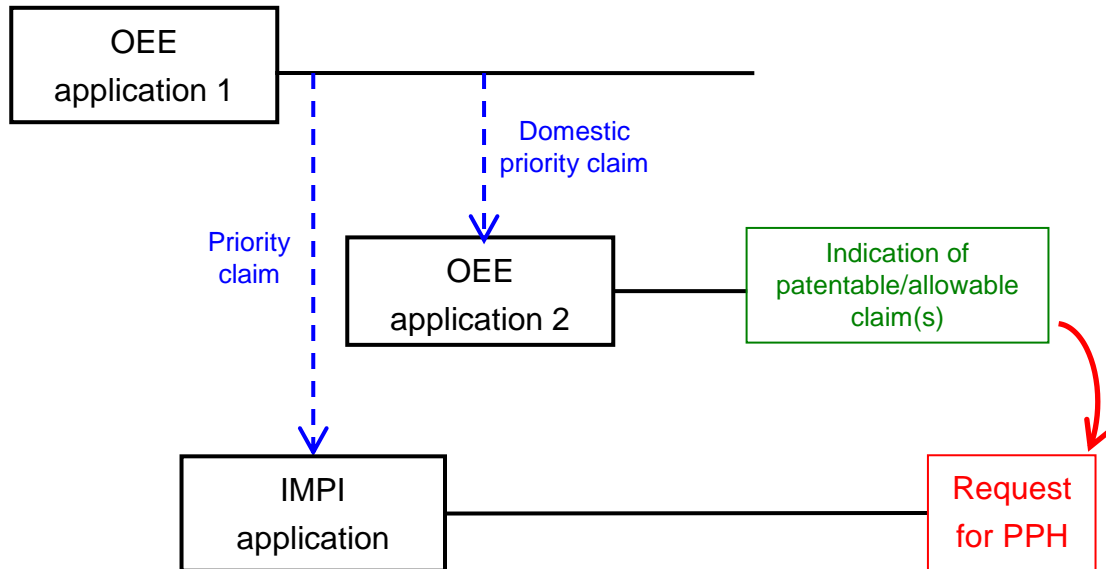

Example H1

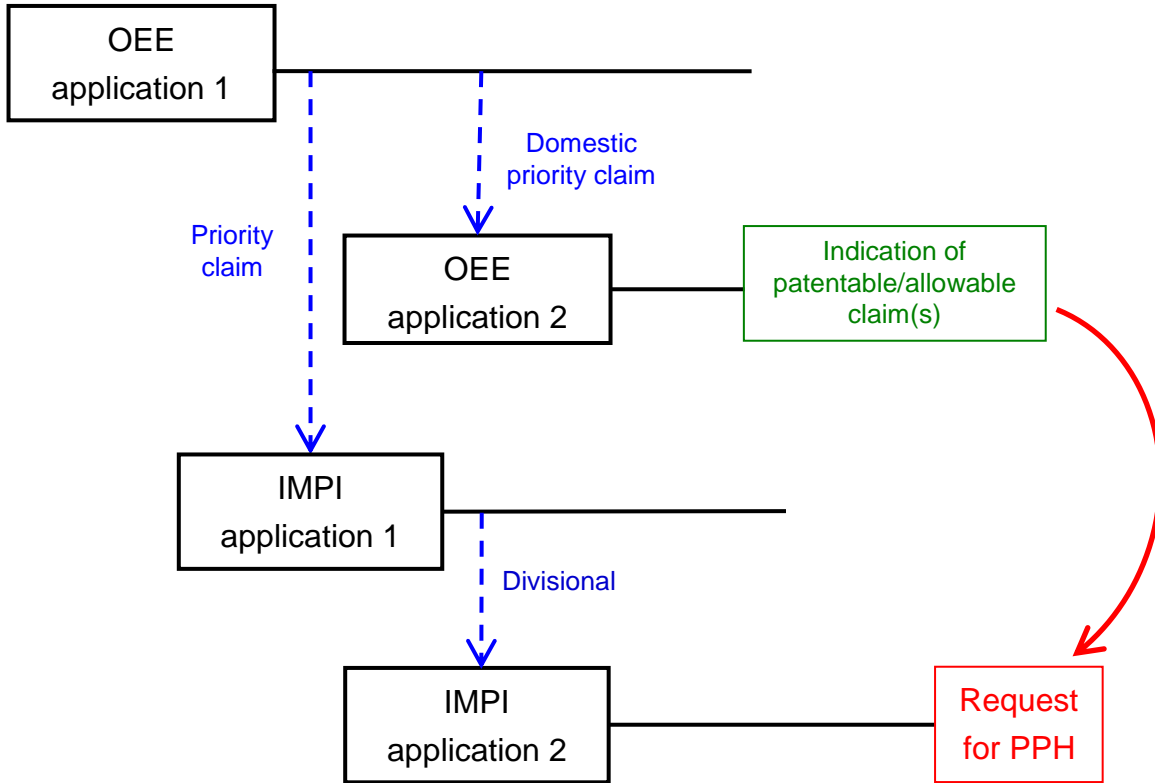

Example I:

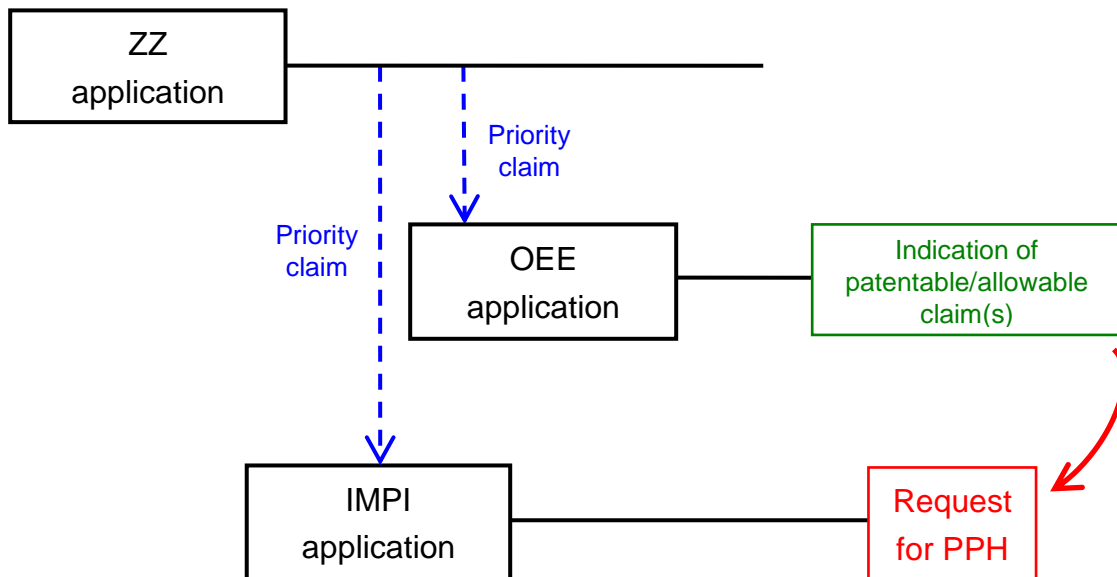

Example J

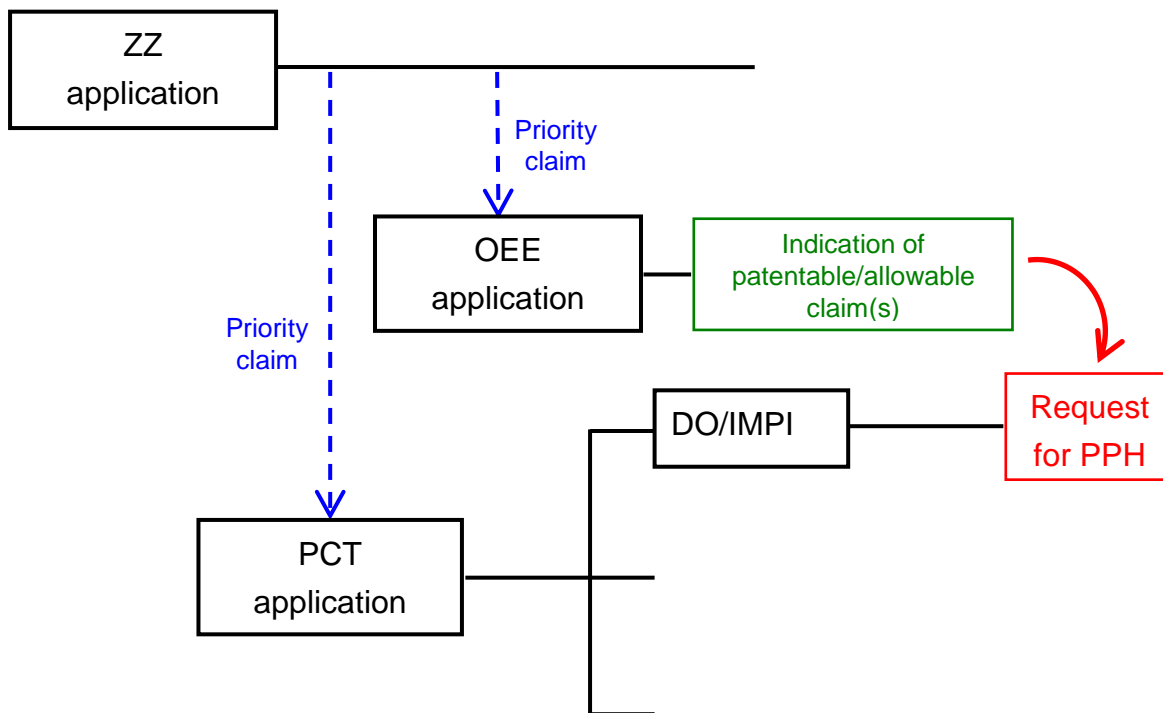

Example K

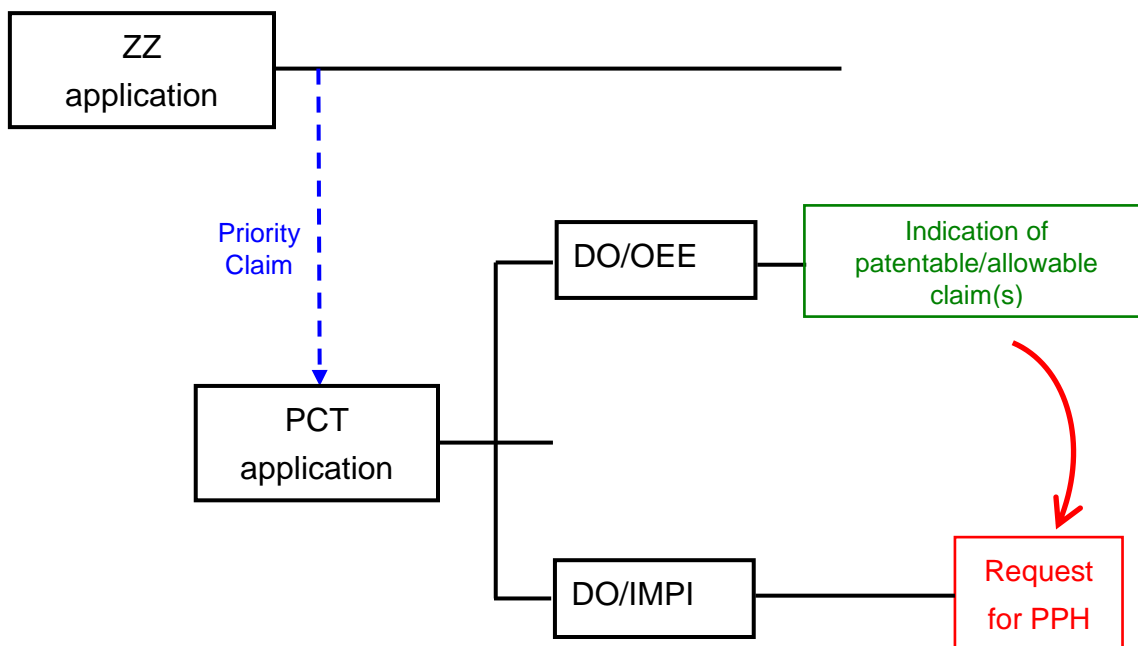

Example L:

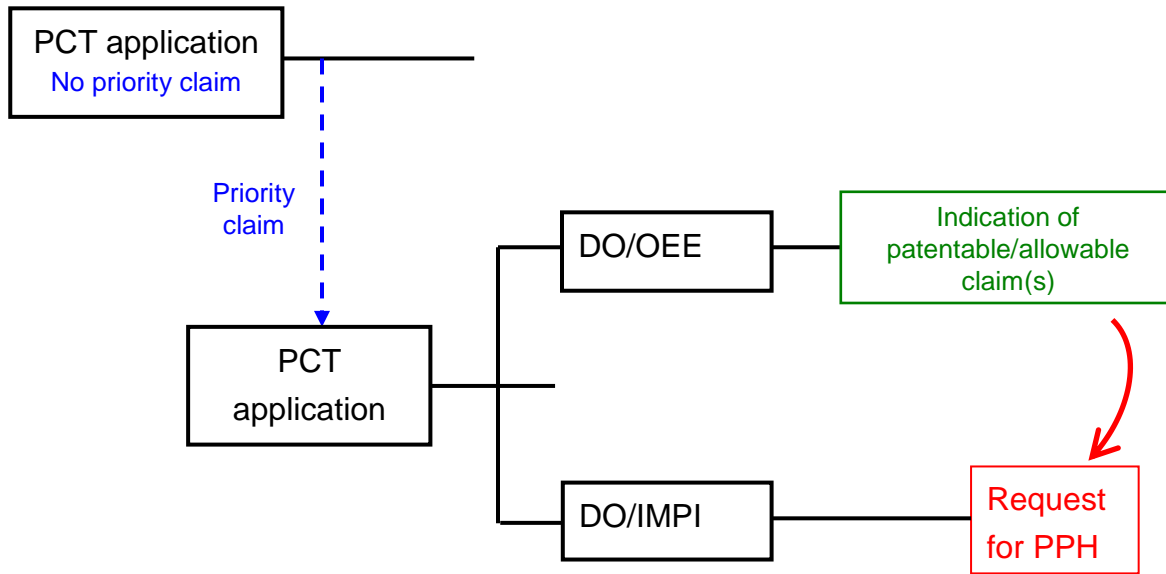

Example M:

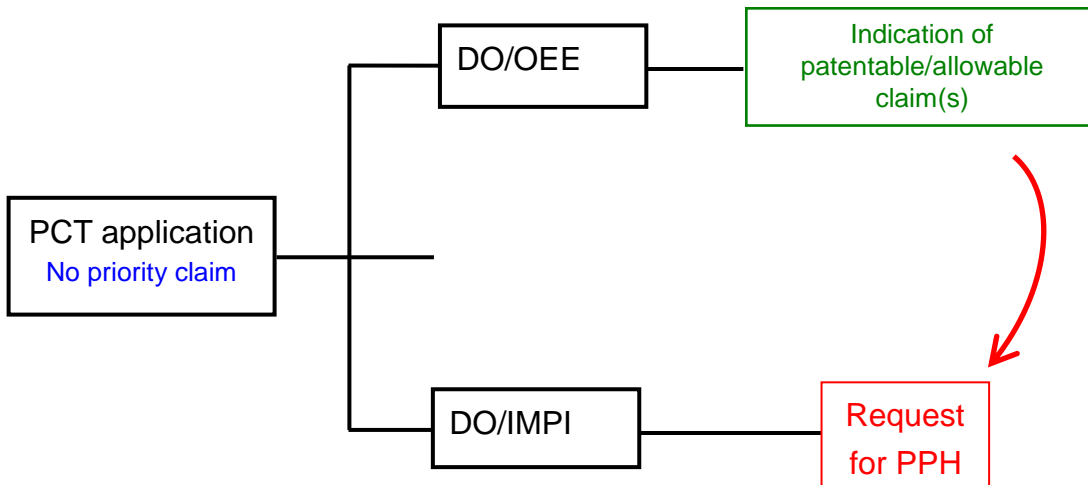

Example N:

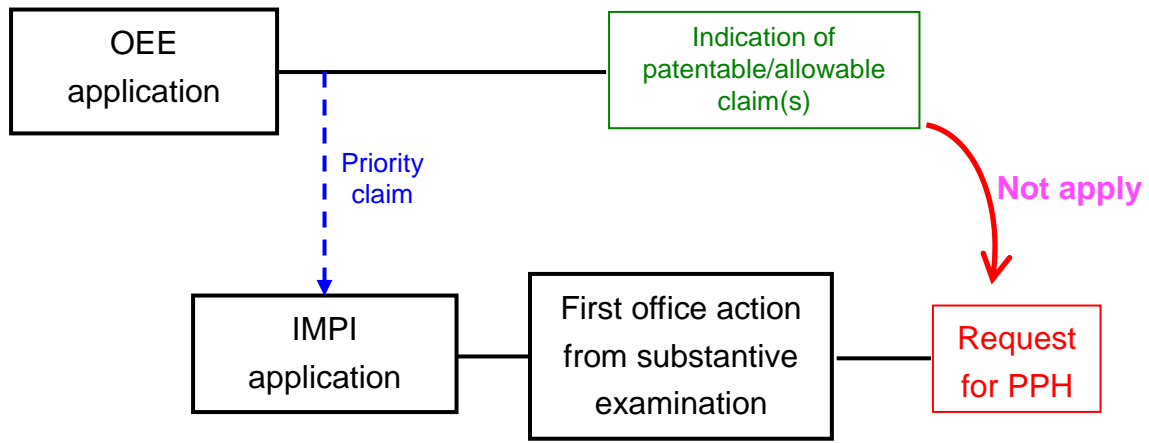

ANNEX II

Examples of Mexican patent applications that may request accelerated examination under the PCT-PPH at the IMPI:

RO is Receiving Office

ZZ is any office

DO is Designated Office.

Example A

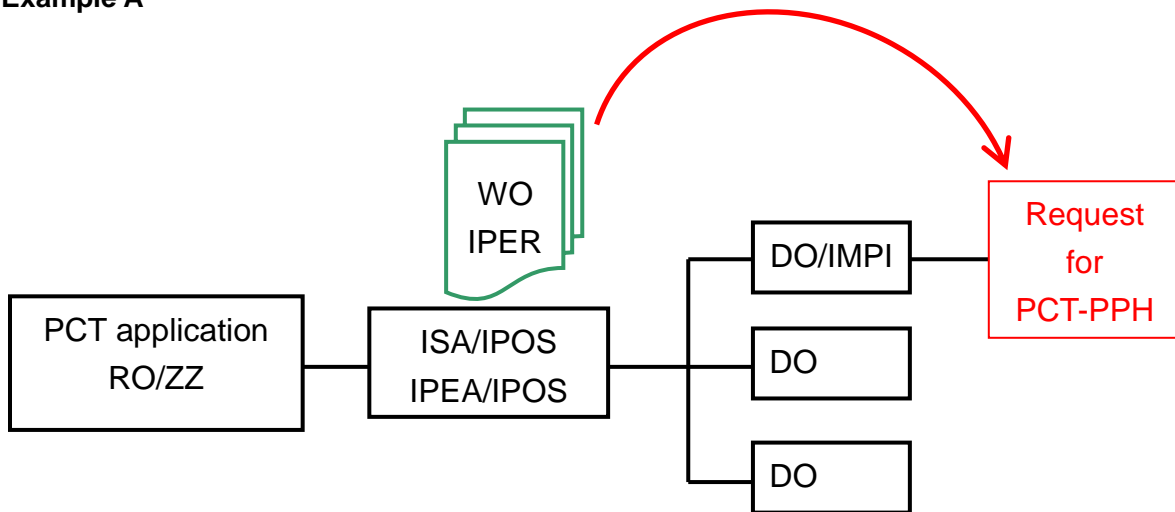

Example A'

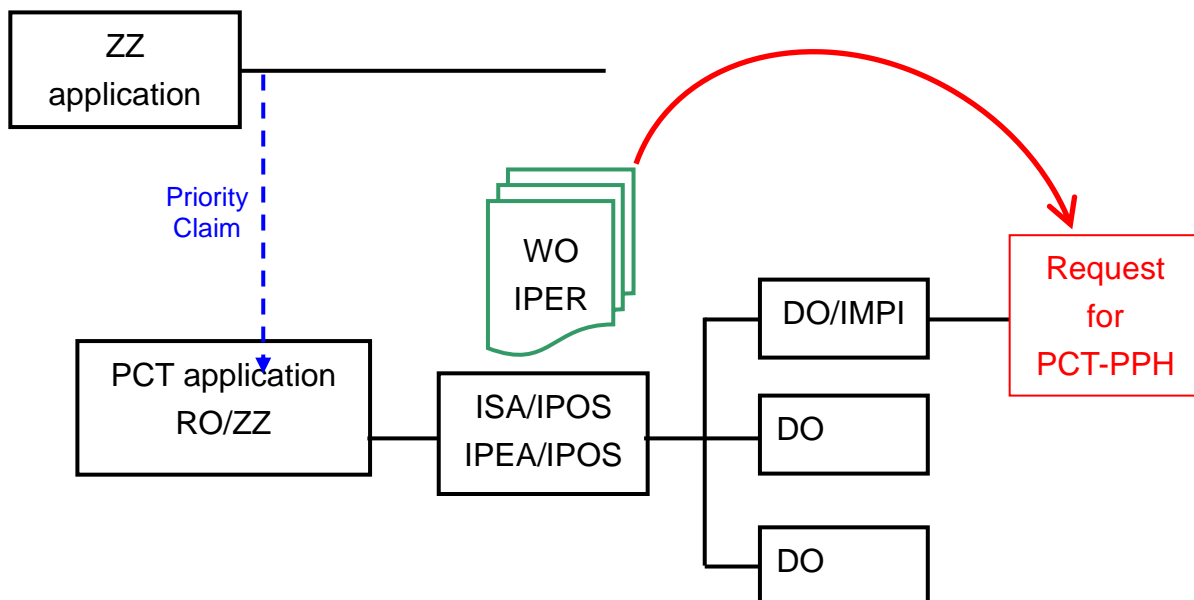

Example A'

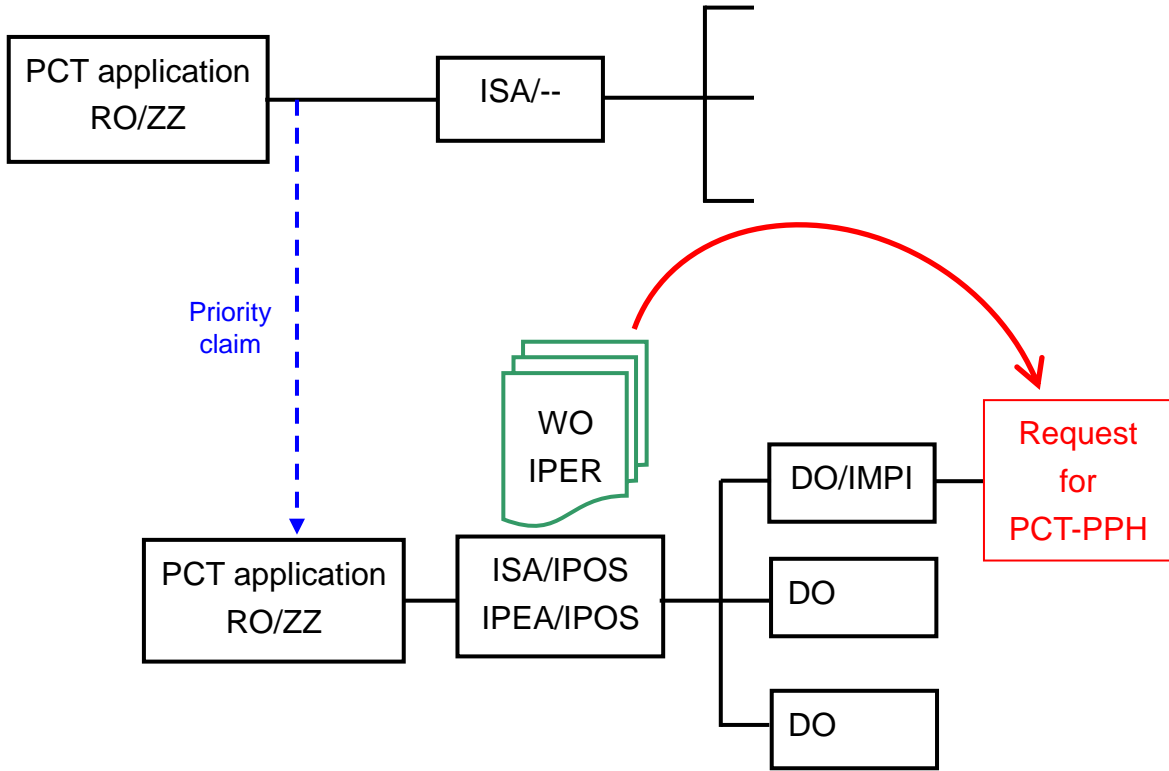

Example B

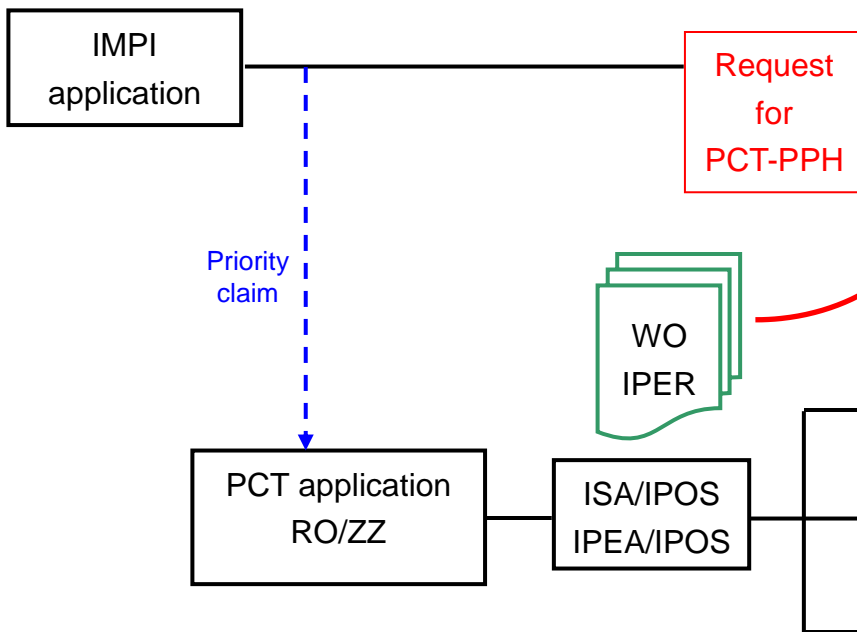

Example C

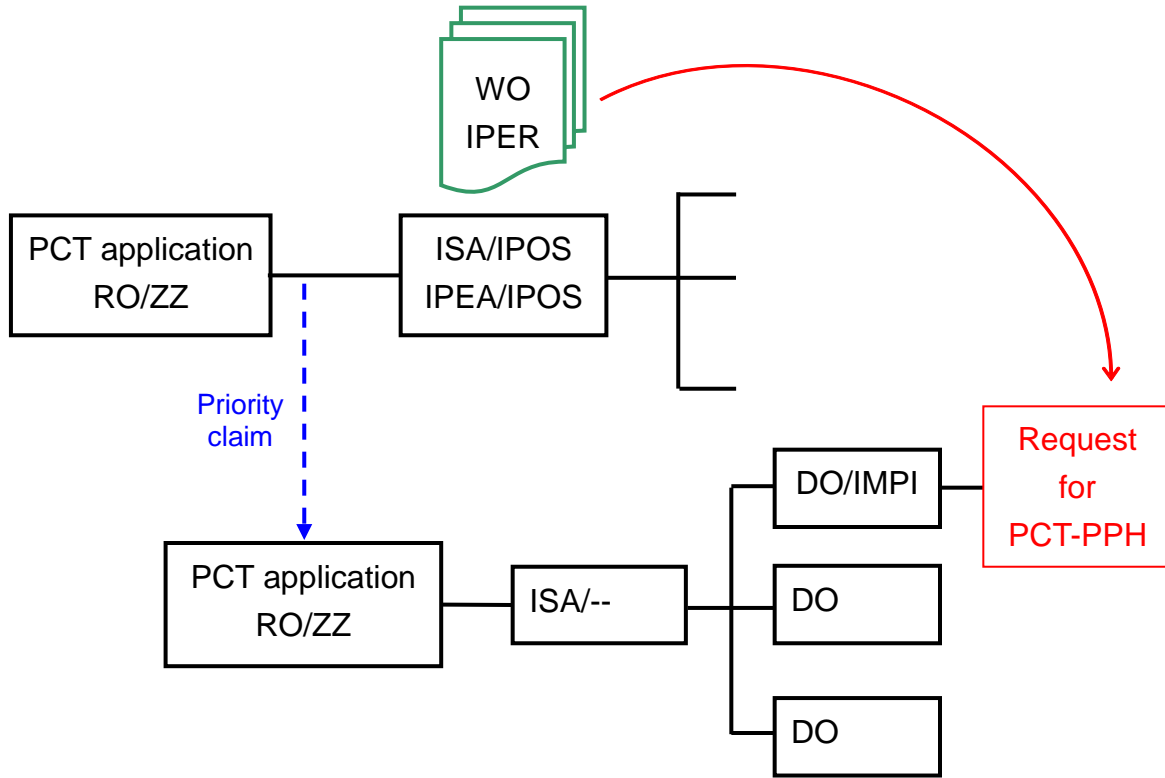

Example D

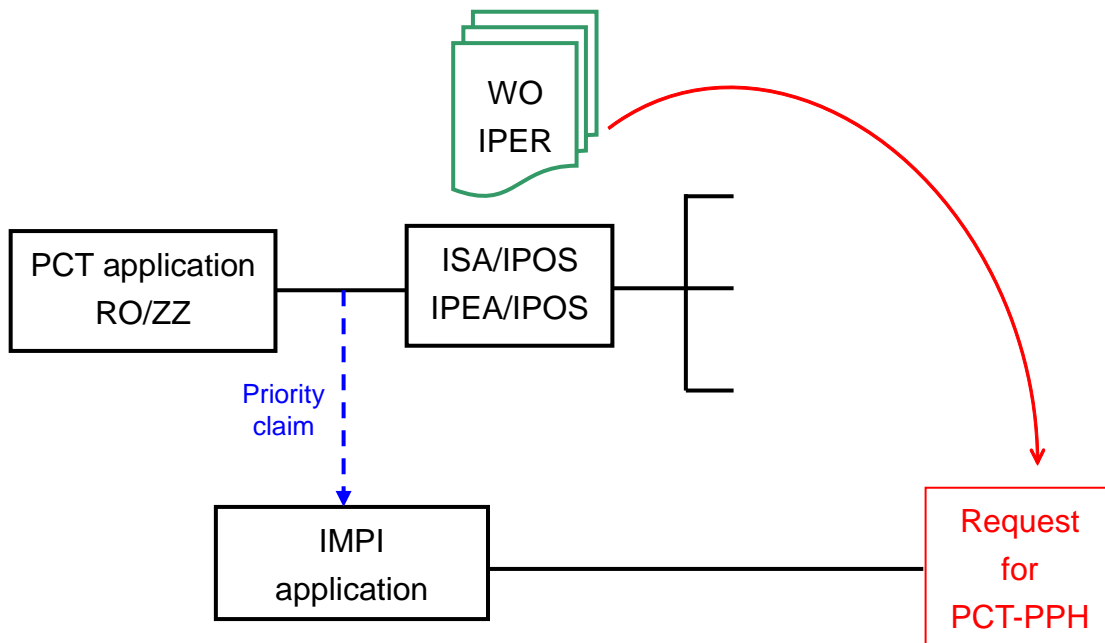

Example E1

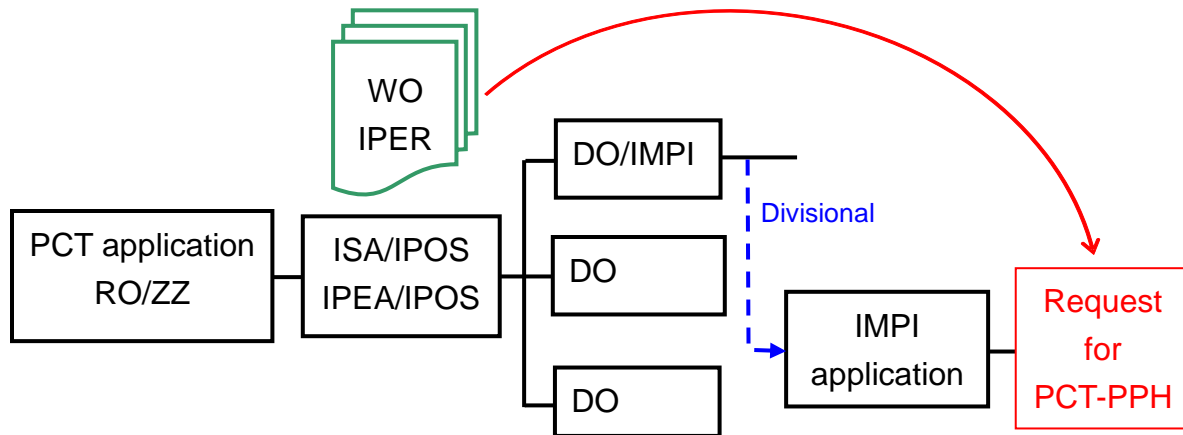

Example E2

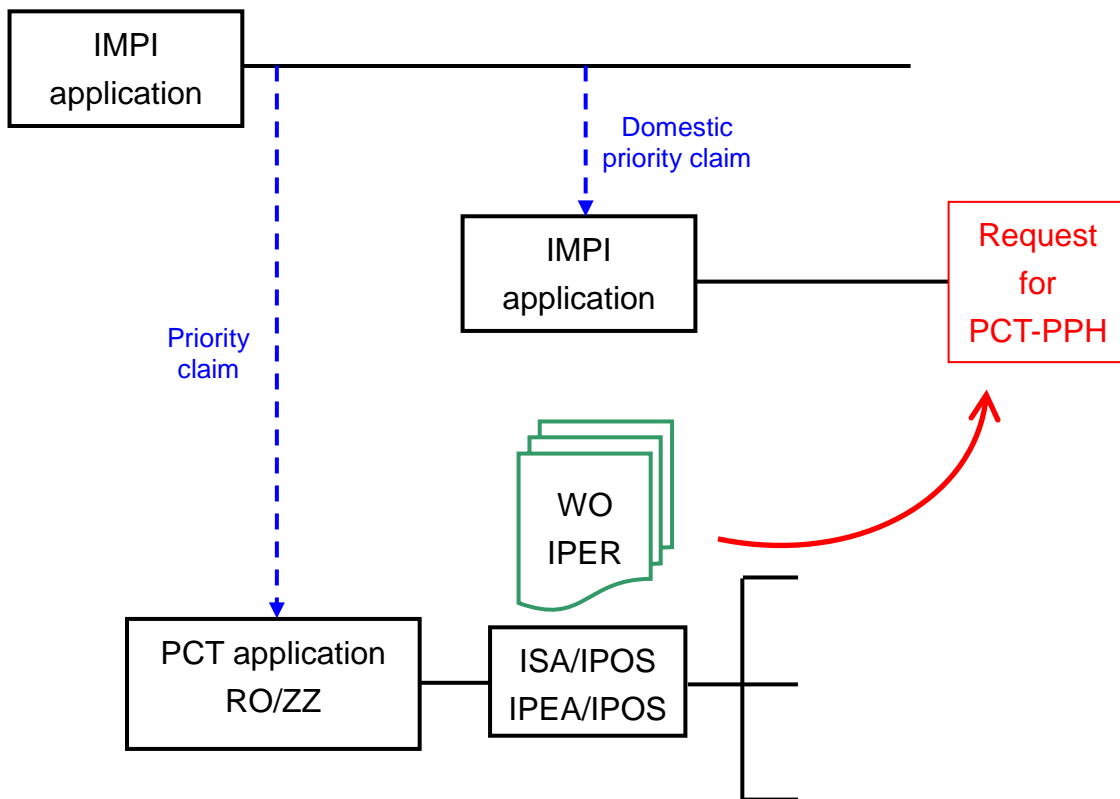

Example E3

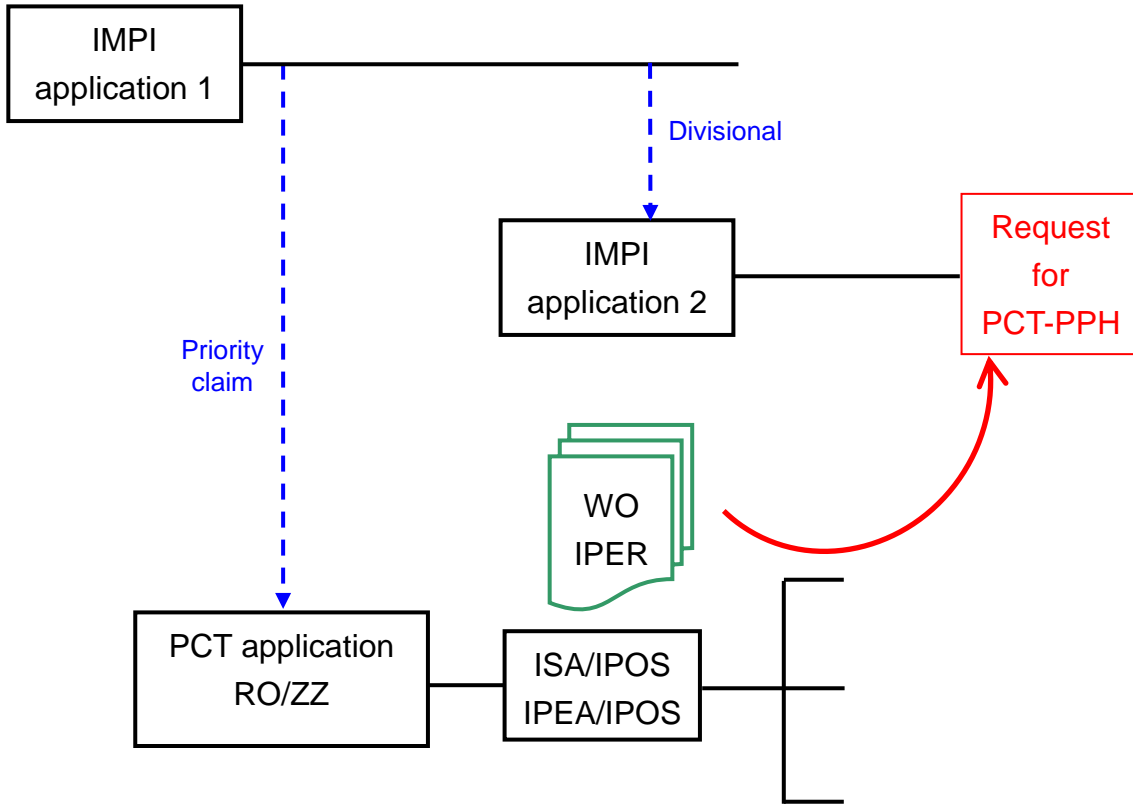

Example F

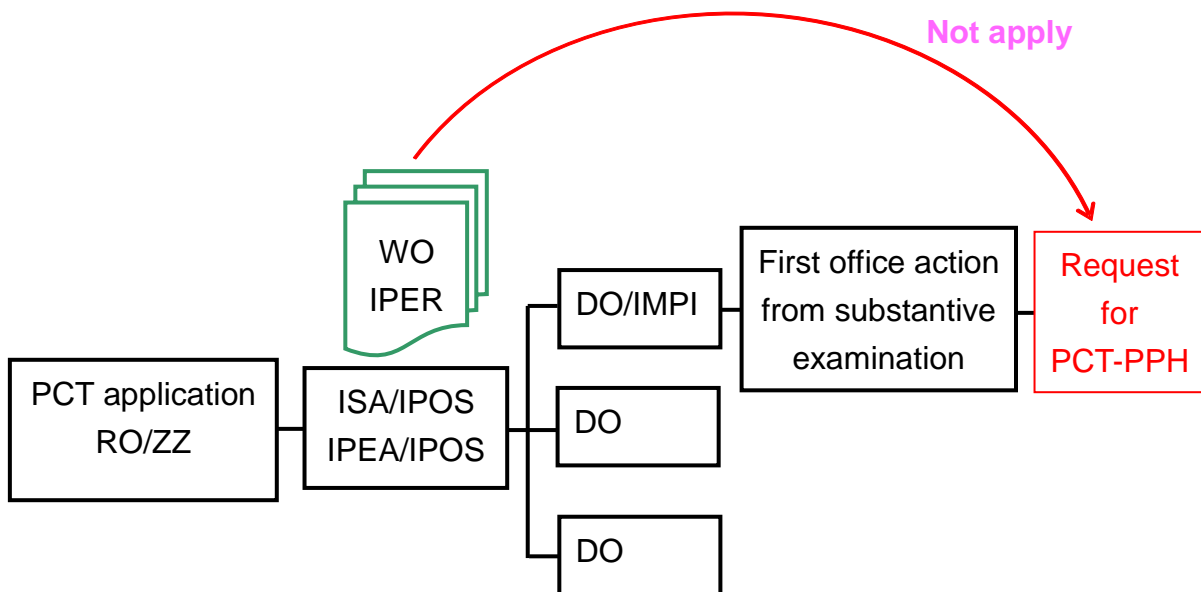

ANNEX III

Examples of cases that are considered "sufficiently correspond" and cases that are not considered "sufficiently correspond".

1. The claims in the following cases (case 1 to 4) are considered “sufficiently correspond”.

Case	Claim(s) “patentable(s)/allowable(s)”		Claim(s) at IMPI		Explanation
	No.	Content	No.	Content	
Case 1	1	A	1	A	IMPI claim 1 is the same as “patentable/allowable” claim 1.
Case 2	1	A	1 2	A A+a	IMPI claim 1 is the same as “patentable/allowable” claim 1. IMPI claim 2 is created by adding a technical feature disclosed in the specification to “patentable/allowable” claim 1.
Case 3	1 2 3	A A+a A+b	1 2 3	A A+b A+a	IMPI claim 1 is the same as “patentable/allowable” claim 1. IMPI claims 2, 3 are the same as “patentable/allowable” claims 3, 2 respectively.
Case 4	1	A	1	A+a	IMPI claim 1 has an additional technical feature “a” disclosed in the specification..

2. The claims in the following cases (case 5 and 6) are not considered “sufficiently correspond”.

Case	Claim(s) “patentable(s)/allowable(s)”		Claims(s) at IMPI		Explanation
	No.	Content	No.	Content	
Case 5	1	A Product	1	A' method	IMPI claim 1 claims to a method, whereas “patentable/allowable” claim 1 claims to a product. (The technical feature of “patentable/allowable” claim is the same as that of IMPI claim, but categories of both claims are different.
Case 6	1	A+B	1	A+C	IMPI claim 1 is different from “patentable/allowable” claim 1 in a component of the claimed invention. (IMPI claim is created by altering part of the technical features of “patentable/allowable” claim.