

Patent Prosecution Highway Pilot Programme between the United States Patent and Trademark Office and the Intellectual Property Office of Singapore

1. Background

To obtain patent protection for an invention in several countries usually requires the invention to be searched and examined in each of the countries. If the patent authorities in these countries were to share the results of their search and/or examination with each other, the opportunity for a patent office to make reference to earlier work done could have several potential benefits:

- Reduced work – Reference to the earlier work done could reduce or even eliminate the need for subsequent search and examination work.
- Faster prosecution – The reduced work could generally lead to a faster prosecution of the patent application.
- Better search and examination – The other patent authorities might have access to databases unavailable (eg specific technical databases, local databases, databases in other languages) to the examiner, therefore the opportunity to refer to these search and examination results could provide the examiner with information on and assessment of prior art that he or she would otherwise not have access to.

2. Patent Prosecution Highway Programme

2.1 The Patent Prosecution Highway (PPH) programme between the United States Patent and Trademark Office (USPTO) and the Intellectual Property Office of Singapore (IPOS) is one way for the two offices to share their search and examination results with each other.

2.2 Where IPOS is the Office of First Filing (OFF) and the Singapore application contains claims that are determined to be allowable/patentable, the applicant may request accelerated examination at the USPTO for the corresponding application filed with the USPTO as the Office of Second Filing (OSF). This is done by petitioning to make the US application special under the PPH pilot programme. The procedures and requirements for filing a request with the USPTO for participation in the PPH pilot program are available from the USPTO Web site at: <http://www.uspto.gov>.

2.3 Where the USPTO is the OFF and the final results of the search and examination or the patent grant of the US application are available, the applicant may request accelerated prosecution of the corresponding application filed with IPOS as the OSF by furnishing certain prescribed information of the US application as set out in the procedures and requirements below. For the avoidance of doubt, the applicant is required to provide all necessary documents to IPOS, and not request that IPOS obtain documents from the USPTO Public PAIR system.

3. Pilot Period for the PPH programme

The PPH pilot programme commences on 2 February 2009, for a period of one year ending on 2 February 2010. This period may be extended for up to an additional year if necessary to adequately assess the feasibility of the PPH programme. The

USPTO and IPOS will evaluate the results of the pilot programme to determine whether and how the programme should be fully implemented after the pilot period. The Offices may also terminate the PPH pilot programme early if the volume of participation exceeds manageable level, or for any other reason. Notice will be published if the PPH pilot programme will be terminated before the 2 February 2010 date.

4. Requirements and procedures for requesting accelerated prosecution of a Singapore patent application

4.1 Requirement 1

The following are the scenarios in which a request for accelerated prosecution of a Singapore application under the PPH pilot programme at IPOS can be made:

- (1) The Singapore application validly claims priority under section 17 of the Singapore Patents Act (Cap. 221) from the US application being relied upon for the PPH request. [See Diagram 1]
- (2) The Singapore application is a divisional application of the Singapore application referred to in (1) above, and the said divisional application validly claims priority under section 17 of the Singapore Patents Act (Cap. 221) from the US application being relied upon for the PPH request. [See Diagram 2]
- (3) The Singapore application validly claims priority under section 17 of the Singapore Patents Act (Cap. 221) from a US application, and the US application being relied upon for the PPH request also validly claims priority under US law from the said earlier US application. [See Diagram 3]
- (4) The Singapore application is a divisional application of the Singapore application referred to in (3) above, and the said divisional application validly claims priority under section 17 of the Singapore Patents Act (Cap. 221) from a US application, and the US application being relied upon for the PPH request also validly claims priority under US law from the said earlier US application. [See Diagram 4]
- (5) The Singapore application is a national phase entry of a PCT application, and the Singapore application validly claims priority under section 17 and section 87 of the Singapore Patents Act (Cap. 221) from a US national application, and it is this US national application that is being relied on for the PPH request. [See Diagram 5]
- (6) The Singapore application is a national phase entry of a PCT application, and the Singapore application validly claims priority under section 17 and section 87 of the Singapore Patents Act (Cap. 221) from a US national application. The US application being relied upon for the PPH request is a national phase entry of the same PCT application, and the US application being relied upon for the PPH request validly claims priority under US law from said US national application. [See Diagram 6]
- (7) There is a first PCT application. There is a second PCT application validly claiming priority from the first PCT application. The Singapore application is a national phase entry of the second PCT application, and the Singapore application validly claims priority under section 17 and section 87 of the

Singapore Patents Act (Cap. 221) from the first PCT application. The US application being relied upon for the PPH request is a national phase entry of the second PCT application, and the US application validly claims priority under US law from the first PCT application. [See Diagram 7]

4.2 Diagrams depicting the above scenarios are in the Annex.

4.3 **Requirement 2**

The Singapore application has not had a valid Patents Form 11C filed, or has not been issued an examination report or a search and examination report pursuant to a Patents Form 12/12(2004) filed or a Patents Form 11/11(2004) filed, respectively.¹

4.4 **The Procedures**

(1) File duly completed Patents Form 11B/11B(2004) and Patents Form 14/14(2004).² These forms can be found at:
<http://www.ipos.gov.sg/topNav/form/Patent+Forms+and+Fees.htm>

(2) The Patents Form 11B/11B(2004) must be accompanied by either:

- a. a copy of the granted patent of the US application being relied upon, duly certified by the USPTO or otherwise acceptable to the Registrar;
or
- b. documents setting out the final results of the search and examination as to substance and a copy of the patent claims referred to in the final results of the US application being relied upon.

(3) If the forms are submitted electronically (whether online or on electronic media), the phrase "USPTO-IPOS PPH acceleration requested" must be inserted in the "Remarks" box of the forms.

(4) If the forms are submitted on paper via the Service Bureau, a cover letter must be submitted with the forms. The cover letter must contain in its title, the phrase "USPTO-IPOS PPH acceleration requested".

(5) All subsequent correspondences with IPOS must be similarly marked with the phrase "USPTO-IPOS PPH acceleration requested".

4.5 Singapore applications which request accelerated prosecution under the PPH pilot programme will be processed in accordance with the Singapore Patents Act (Cap. 221) and the Singapore Patents Rules. The legislations can be found at:
<http://www.ipos.gov.sg/topNav/leg/Statutory+Acts.htm>.

4.6 Applicants should seek professional advice on patent matters in Singapore, in particular, with reference to section 30 (Grant of patent) and section 69 (Restrictions on relief for infringement) of the Singapore Patents Act (Cap. 221).

¹ The non "2004" forms are to be used for Singapore applications with a date of filing before 1 July 2004). The "2004" forms are to be used for Singapore applications with a date of filing on or after 1 July 2004.

² Ibid.

5. Enquiries

For enquiries relating to the Patent Prosecution Highway pilot programme between the USPTO and IPOS, please contact Ms Linda Bernadatte Mitchell of IPOS via telephone (65) 63308 609 or email linda_bernadatte_mitchell@ipos.gov.sg with the subject heading "USPTO-IPOS PPH".

INTELLECTUAL PROPERTY OFFICE OF SINGAPORE

DATE: 2 February 2009

Annex

Diagrams of SG applications that fall under Scenario (1):

Diagram 1: The Singapore application validly claims priority under section 17 of the Singapore Patents Act (Cap. 221) from the US application being relied upon for the PPH request.

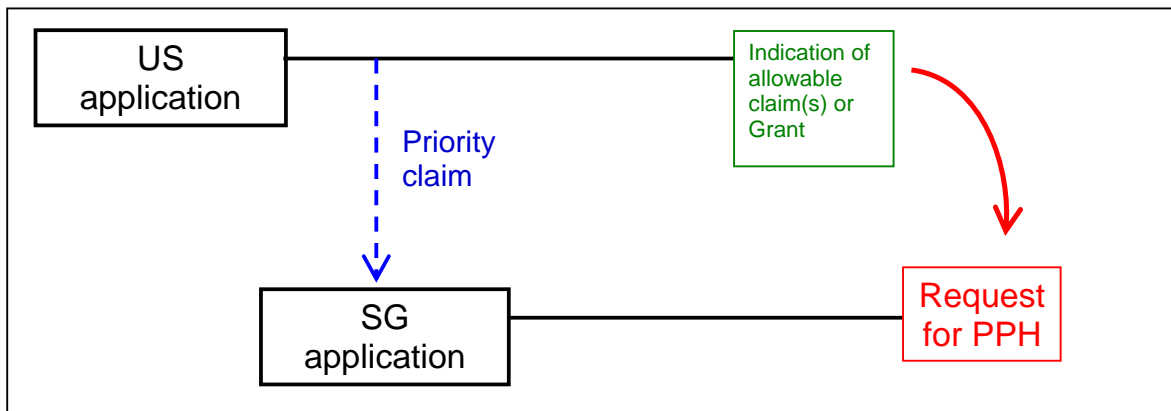

Diagram of SG applications that fall under Scenario (2):

Diagram 2: The Singapore application is a divisional application of the Singapore application referred to in (1) above, and the said divisional application validly claims priority under section 17 of the Singapore Patents Act (Cap.221) from the US application being relied upon for the PPH request.

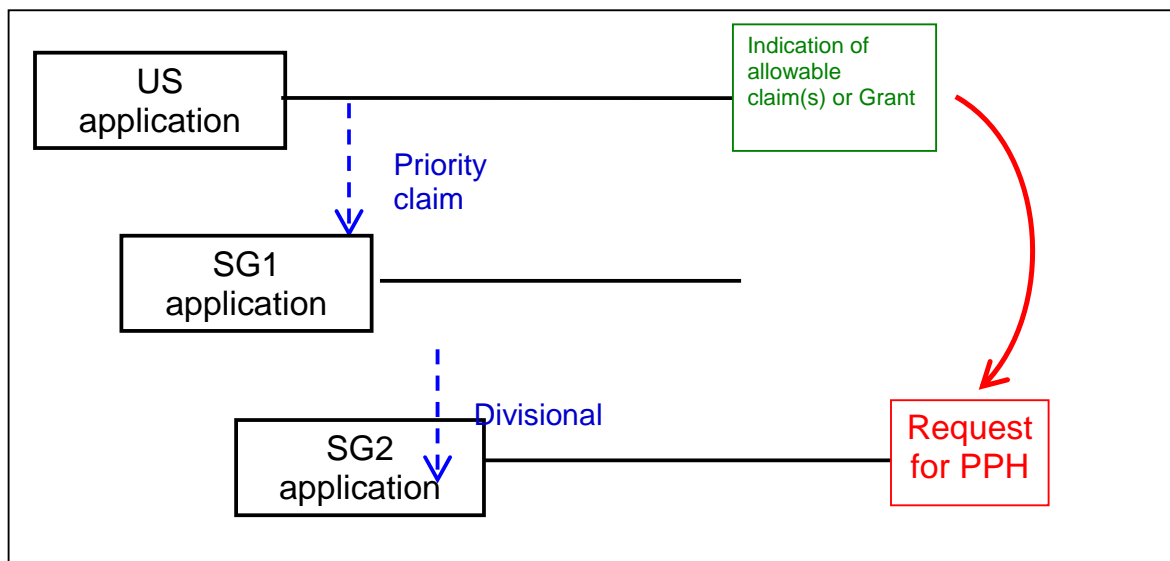

Diagram of SG applications that fall under Scenario (3):

Diagram 3: The Singapore application validly claims priority under section 17 of the Singapore Patents Act (Cap.221) from a US application, and the US application being relied upon for the PPH request also validly claims priority under US law from the said earlier US application.

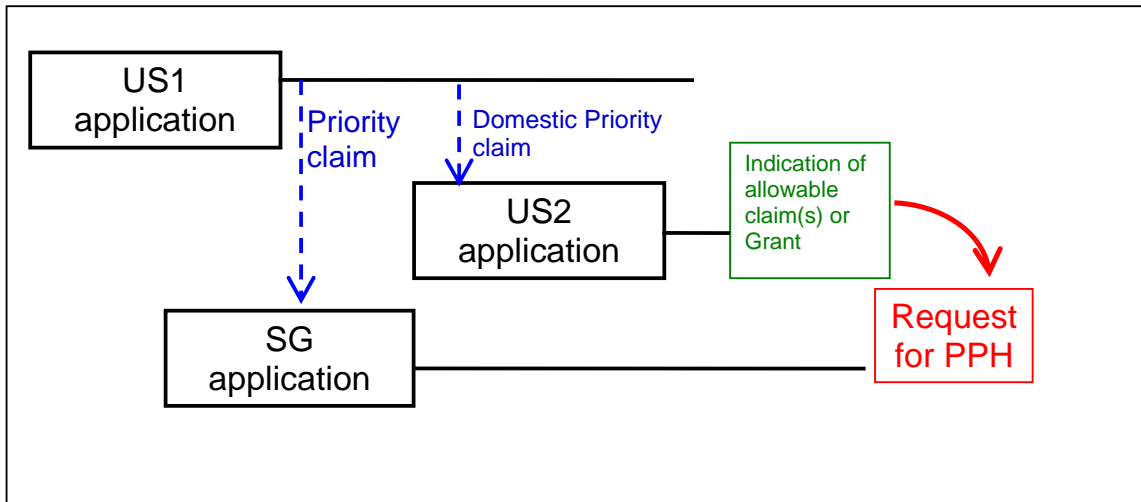

Diagram of SG applications that fall under Scenario (4):

Diagram 4: The Singapore application is a divisional application of the Singapore application referred to in (3) above, and the said divisional application validly claims priority under section 17 of the Singapore Patents Act (Cap.221) from a US application, and the US application being relied upon for the PPH request also validly claims priority under US law from the said earlier US application.

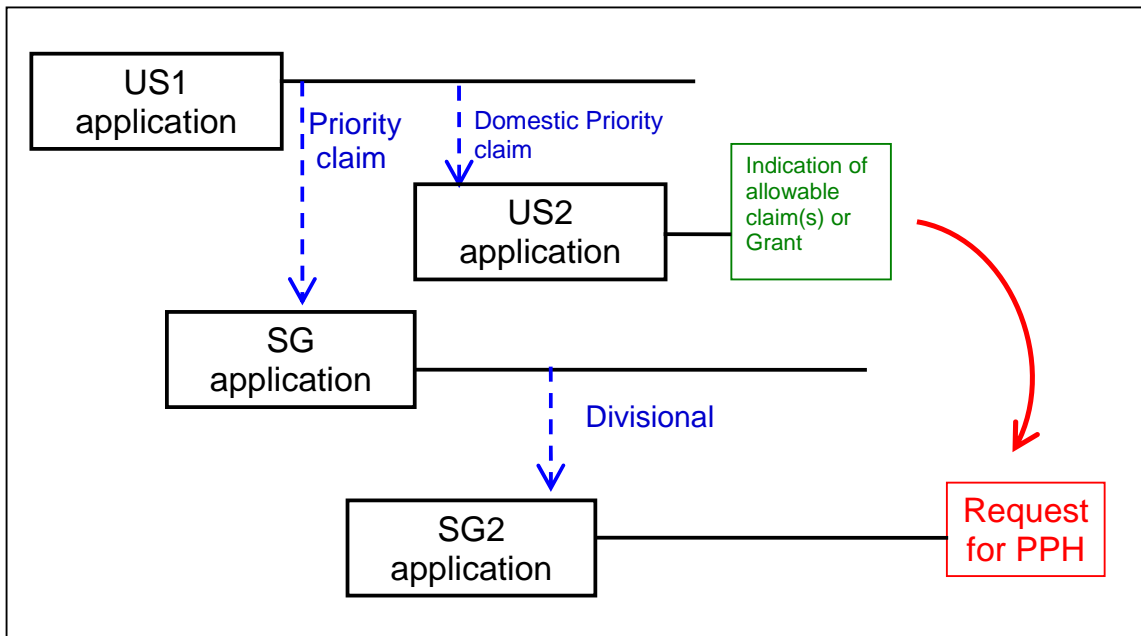

Diagram of SG applications that fall under Scenario (5):

Diagram 5: The Singapore application is a national phase entry of a PCT application, and the Singapore application validly claims priority under section 17 and section 87 of the Singapore Patents Act (Cap. 221) from a US national application, and it is this US national application that is being relied on for the PPH request.

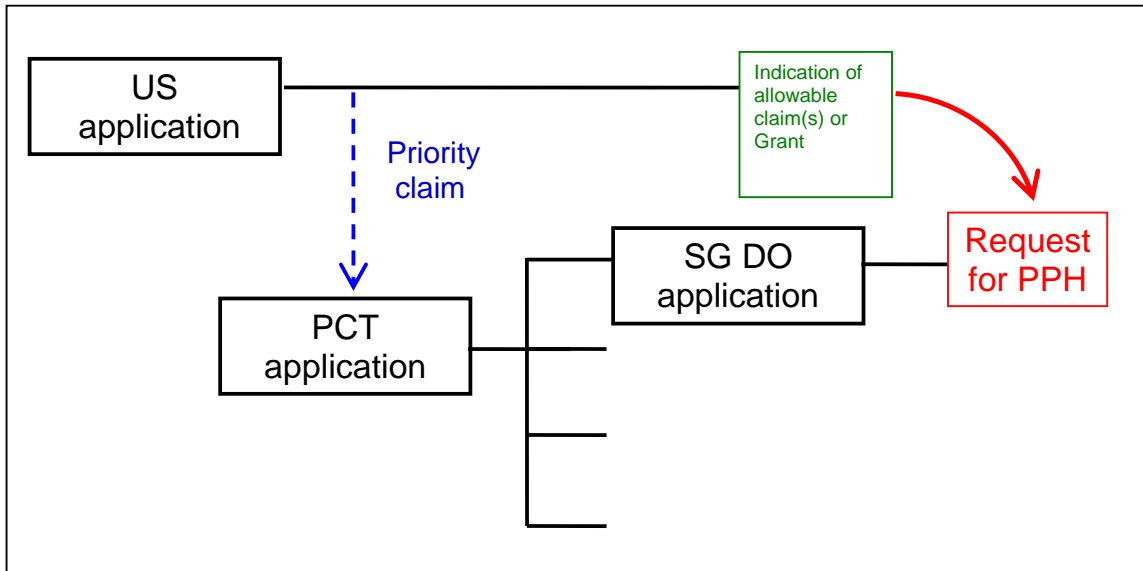

Diagram of SG applications that fall under Scenario (6):

Diagram 6: The Singapore application is a national phase entry of a PCT application, and the Singapore application validly claims priority under section 17 and section 87 of the Singapore Patents Act (Cap. 221) from a US national application. The US application being relied upon for the PPH request is a national phase entry of the same PCT application, and the US application being relied upon for the PPH request validly claims priority under US law from said US national application.

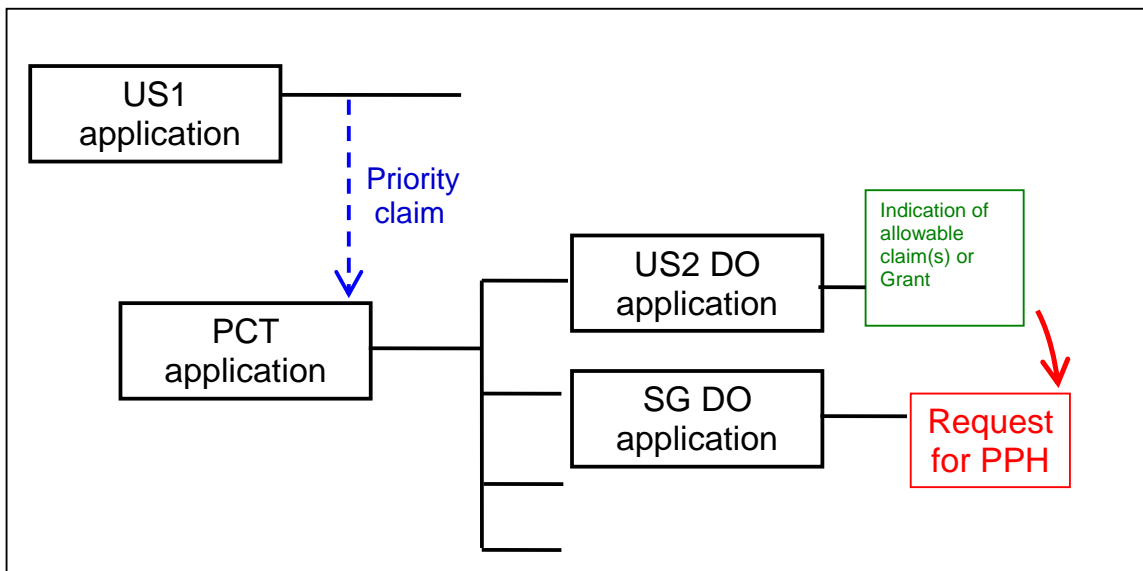

Diagram of SG applications that fall under Scenario (7):

Diagram 7: There is a first PCT application. There is a second PCT application validly claiming priority from the first PCT application. The Singapore application is a national phase entry of the second PCT application, and the Singapore application validly claims priority under section 17 and section 87 of the Singapore Patents Act (Cap. 221) from the first PCT application. The US application being relied upon for the PPH request is a national phase entry of the second PCT application, and the US application validly claims priority under US law from the first PCT application.

