

Patent Prosecution Highway Pilot Programme between the Intellectual Property Office of Singapore and the National Institute of Industrial Property of Brazil

1. Background

- 1.1 To obtain patent protection for an invention in several countries usually requires the invention to be searched and examined in each of the countries. If the patent authorities in these countries were to share the results of their search and/or examination with each other, the opportunity for a patent office to refer to earlier work done could have several potential benefits:
- (a) **Reduced work** – Reference to the earlier work done could reduce or even eliminate the need for subsequent search and examination work.
 - (b) **Accelerated examination** – The reduced work could generally lead to a faster examination of the patent application.
 - (c) **Better search and examination** – Other patent offices might have access to databases unavailable (e.g. specific technical databases, local databases, databases in other languages) to the examiner, therefore the opportunity to refer to these search and examination results could provide the examiner with information on and assessment of prior art that he or she would otherwise not have access to.

2. Patent Prosecution Highway Programme

- 2.1 The Patent Prosecution Highway (PPH) programme between the Intellectual Property Office of Singapore (IPOS) and the National Institute of Industrial Property of Brazil (INPI) allows the two offices to share their search and examination results with each other.
- 2.2 Where IPOS is the Office of Earlier Examination (OEE) and the IPOS application contains claims that are determined to be allowable/patentable, the applicant may request accelerated examination at the INPI for the corresponding application filed with the INPI as the Office of Later Examination (OLE) (*Mottainai model*). The requirements and procedures for filing a request with the INPI for participation in the PPH pilot programme are available from the INPI website at the following links:
- <https://www.gov.br/inpi/pt-br/central-de-conteudo/noticias/projeto-piloto-pph-do-brasil-com-singapura-esta-em-vigor>
 - <https://www.gov.br/inpi/pt-br/backup/pph>
- 2.3 Where the INPI is the OEE and the INPI application contains claims that are determined to be allowable/patentable¹, the applicant may request accelerated examination of the corresponding application filed with IPOS as the OLE by furnishing certain information of the IPOS application as set out in the requirements and procedures below.

3. PPH Pilot Programme Commencement

- 3.1 The PPH pilot programme commences on 1 May 2020 for a period of 5 years, ending on 30 April 2025.

¹ Allowed claims from a utility model or a petty patent cannot be used to form the basis for requesting PPH in IPOS.

- 3.2 IPOS will evaluate the results of the pilot programme to determine whether and how the programme should be fully implemented. IPOS may terminate the PPH pilot programme if the volume of participation exceeds manageable level, or for any other reason. Notice will be published if the PPH pilot programme will be terminated.
- 4. Requirements for requesting accelerated examination of an IPOS patent application under the PPH**
- 4.1 The INPI application has at least one claim that is determined to be allowable/patentable by the INPI.
- 4.2 All claims in the IPOS application must sufficiently correspond or be amended to sufficiently correspond to one or more of the claims found allowable/patentable by the INPI. Claims will be considered to sufficiently correspond where, accounting for differences due to translations and claim format, the claims are of the same or similar scope, or the claims are narrower in scope. In this regard, a claim that is narrower in scope occurs when a claim in the IPOS application is amended to be further limited by an additional technical feature that is supported in the specification.
- 4.3 Examination has not begun on the IPOS application.
- 4.4 Diagrams depicting a list of scenarios in which a request for accelerated examination of the IPOS application can be made under the PPH pilot programme are found in Annex I.
- 5. Procedures for requesting accelerated examination of an IPOS patent application under the PPH**
- 5.1 File duly completed Patents Form 11 (Request for Search and Examination Report) or Patents Form 12 (Request for Examination Report). These forms can be found at: <https://digitalhub.ipos.gov.sg/> (electronic platform for online filing).
- 5.2 The Patents Form 11 or Patents Form 12 must be accompanied by:
- (a) a copy of all office actions of the INPI application being relied upon;
 - (b) a copy of the allowable/patentable patent claims referred to in (a) above; and
 - (c) a claims correspondence table showing the relatedness of the allowable/patentable claims referred to in (a) above to the claims in the current IPOS application. The format of the Claims Correspondence Table is found in Annex II.
- 5.3 The documents listed in 5.2 (a) can be either the:
- (a) national work product including (i) written opinion established by the INPI as the national Office or (ii) examination report and decision of grant established by the INPI as the national Office during the processing of a national application or a Patent Cooperation Treaty (PCT) application that has entered the national phase before the INPI; or
 - (b) PCT work product including (i) written opinion established by the INPI International Searching Authority or International Preliminary Examining Authority or (ii) the international preliminary examination report issued within the framework of the PCT.

- 5.4 If the documents listed in 5.2(a) and 5.2(b) above are available in the INPI Dossier Access System or the World Intellectual Property Organisation's PATENTSCOPE system, they need not be filed with the Patents Form 11 or Patents Form 12. The INPI Dossier Access System is accessible via <http://www.inpi.gov.br/>. The PATENTSCOPE system is accessible via <http://www.wipo.int/pctdb/en/index.jsp>.
- 5.5 For avoidance of doubt, a copy of the patent grant without the documents listed in (a) and (b) in 5.2 above will not qualify for the PPH.
- 5.6 The checkbox for "ASPEC/PPH" must be selected in the Patents Form 11 or Patents Form 12.
- 5.7 If the request for PPH is sought after the Patents Form 11 or Patents Form 12 is filed, an email must also be sent to IPOS at PT_acceleration@ipos.gov.sg. The email must contain in its subject, the title "PPH acceleration requested" and should also inform whether any amendments are required to conform the Singapore claims to the foreign allowed claims. Upon receipt of the email, IPOS will advise if examination has started on the IPOS application, and if examination has not started, we will invite the applicant to submit the relevant PPH documents in 5.2 via ad-hoc correspondence at <https://digitalhub.ipos.gov.sg/>.
- 5.8 Any subsequent correspondences with IPOS must also be marked with the phrase "PPH acceleration requested".
- 5.9 The documents in paragraph 5.2 must be accompanied by an English translation if they are not originally in English, at the time of filing the PPH request².

6. Cited Documents

- 6.1 A copy of each of the documents cited in the documents submitted under paragraph 5.2 (a) is not required at the time of filing the PPH request. IPOS may, however, require the applicant to furnish a copy of any document cited subsequently.
- 6.2 The cited documents may be filed in their original language. However, IPOS may subsequently request for an English translation of a document or a part of a document if an English abstract of the cited document is not available.

7. PPH Request

- 7.1 IPOS will treat a PPH request as a request for accelerated examination under the PPH pilot programme. Where the PPH request is granted, the IPOS application will be processed in an accelerated manner. In those instances, where the PPH request does not meet all the requirements and procedures set forth above, the applicant will be notified and the defects in the request will be identified. The applicant will be given one opportunity to correct formal deficiencies identified in the request. If the request is not corrected, the application will be taken out of the PPH programme and the applicant will be notified.

8. Examination of IPOS patent application under the PPH pilot

- 8.1 The IPOS application will be examined in accordance with the Singapore Patents Act (Cap. 221) and the Singapore Patents Rules. The legislations can be found at: <https://www.ipos.gov.sg/resources/ip-legislation>.

² If it is not possible for IPOS to understand the English translation of any document, IPOS can request the applicant to resubmit the English translation of that document.

8.2 Applicants should seek professional advice on patent matters in Singapore, in particular, with reference to section 30 (Grant of patent) and section 69 (Restrictions on relief for infringement) of the Singapore Patents Act (Cap. 221).

9. Enquiries

9.1 For enquiries relating to the Patent Prosecution Highway pilot programme, please send an email to PT_acceleration@ipos.gov.sg.

INTELLECTUAL PROPERTY OFFICE OF SINGAPORE

DATE: 2 June 2022

Last updated: July 2023

Annex I

Scenarios using the National Work Product

Scenario (1): The IPOS application validly claims priority under section 17 of the Singapore Patents Act (Cap. 221) from the INPI application being relied upon for the PPH request.

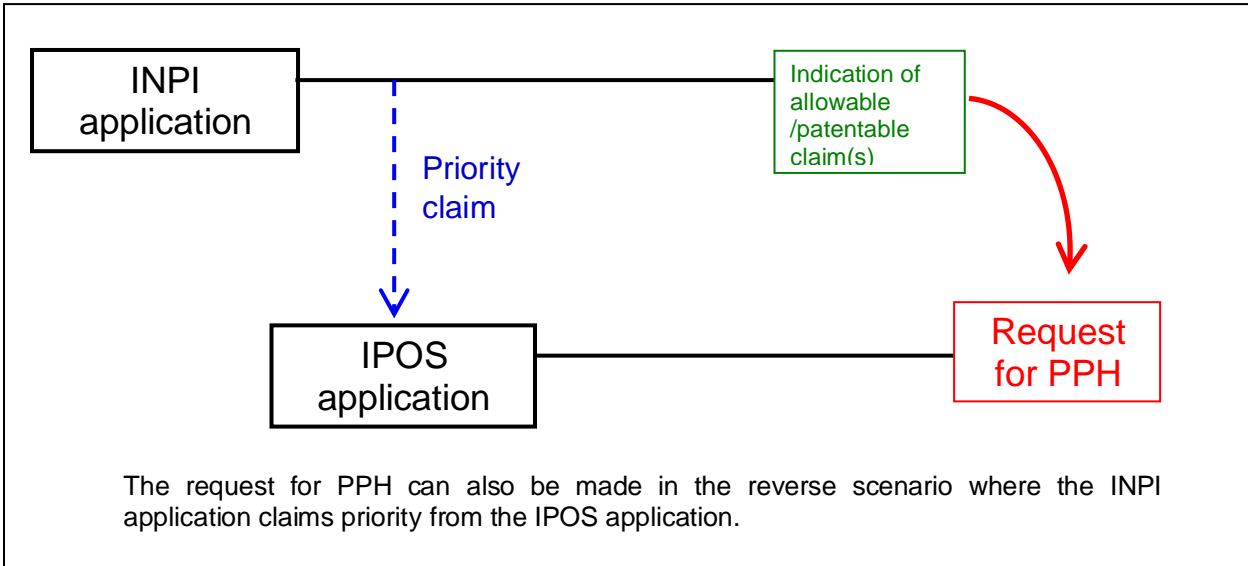

Scenario (2): The IPOS application validly claims priority under section 17 of the Singapore Patents Act (Cap. 221) from the INPI application being relied upon for the PPH request and applications filed in any office other than the IPOS or the INPI.

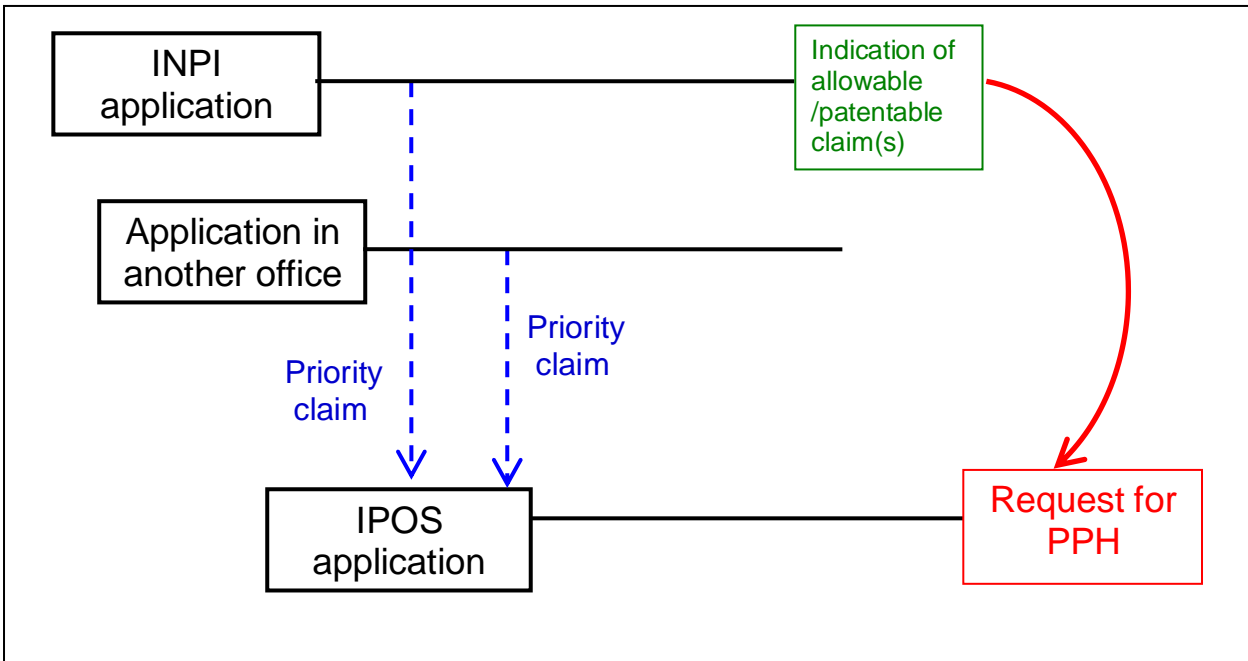

Scenario (3): The IPOS application is a divisional application of the IPOS application referred to in (1) above, and said divisional application validly claims priority under section 17 of the Singapore Patents Act (Cap. 221) from the INPI application being relied upon for the PPH request.

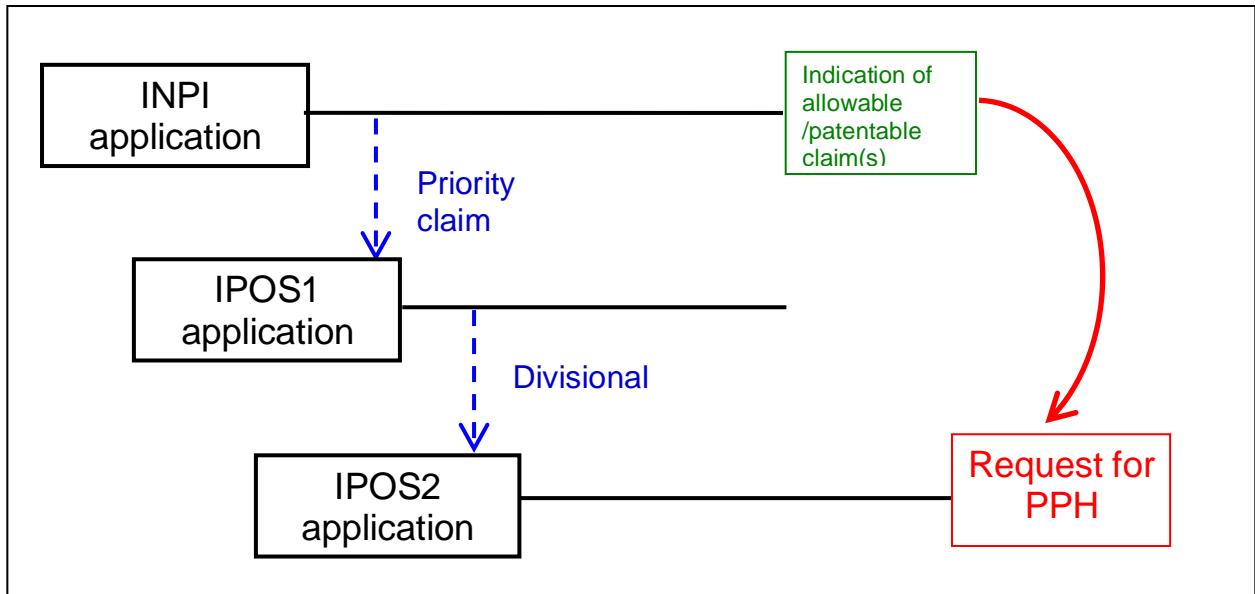

Scenario 4: The IPOS application validly claims priority under section 17 of the Singapore Patents Act (Cap. 221) from an INPI application, and the INPI application being relied upon for the PPH request also validly claims priority under Brazilian law from said earlier INPI application.

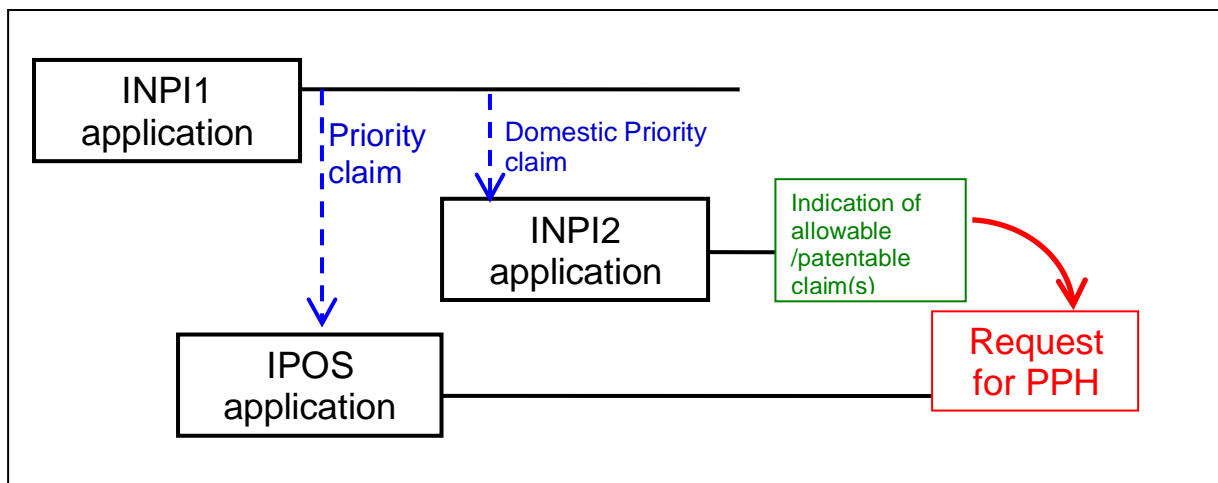

Scenario 5: The IPOS application is a divisional application of the IPOS application referred to in (3) above, and said divisional application validly claims priority under section 17 of the Singapore Patents Act (Cap. 221) from the INPI application, and the INPI application being relied upon for the PPH request also validly claims priority under the Brazilian Patent law from said earlier INPI application.

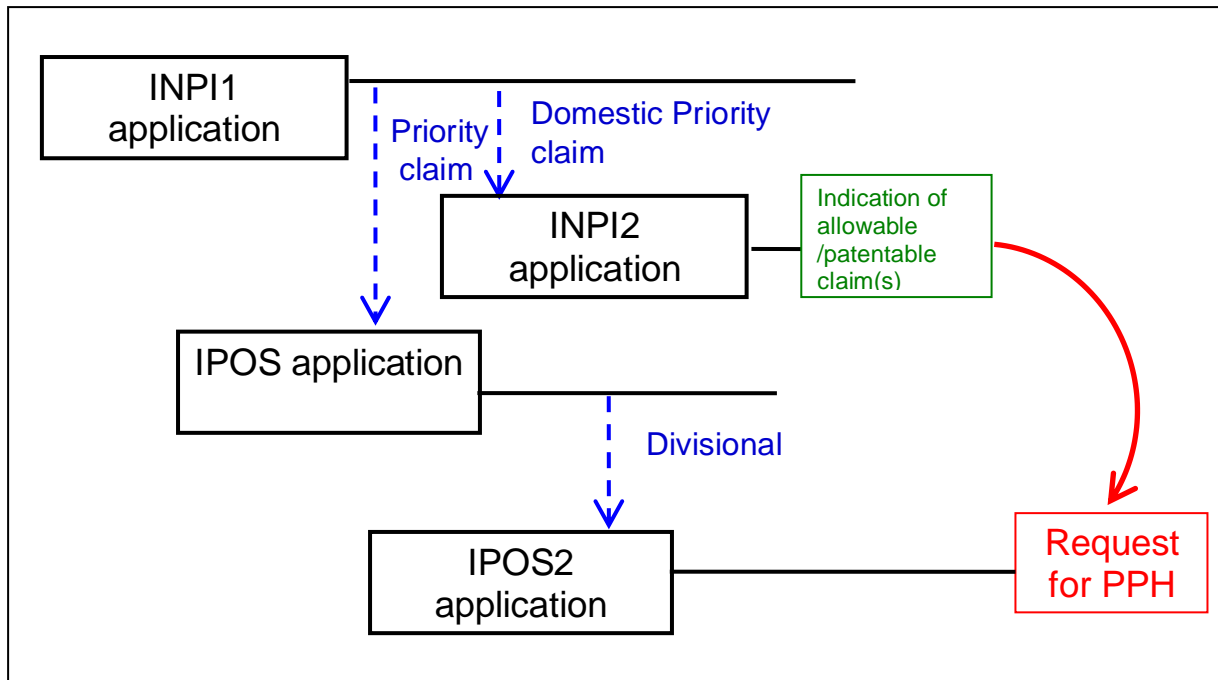

Scenario 6: The IPOS application validly claims priority under section 17 of the Singapore Patents Act (Cap. 221) from a PCT application. The INPI application being relied upon for the PPH request is a national phase entry of the PCT application.

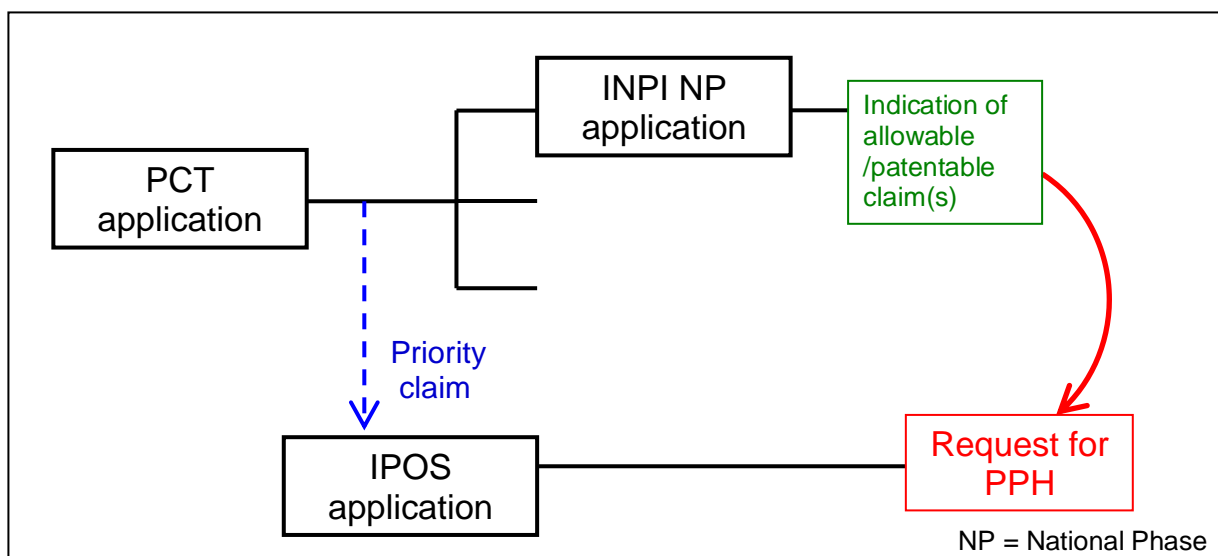

Scenario (7): The IPOS application is a national phase entry of a PCT application (“IPOS NP application”), and the IPOS application validly claims priority under section 17 and section 87 of the Singapore Patents Act (Cap. 221) from the INPI application. The INPI application is being relied on for the PPH request.

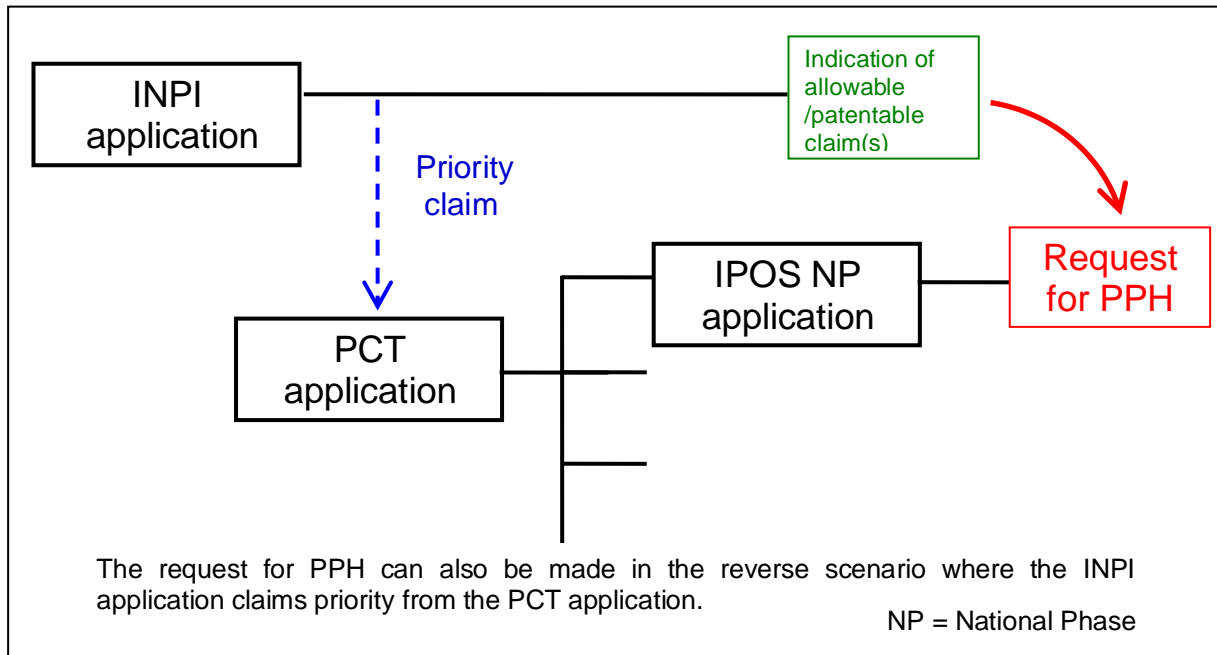

Scenario (8): The IPOS application is a national phase entry of a PCT application (“IPOS NP application”), and the IPOS application validly claims priority under section 17 and section 87 of the Singapore Patents Act (Cap. 221) from the INPI application (“INPI1 application”). The INPI application being relied upon for the PPH request (“INPI2 NP application”) is a national phase entry of the same PCT application, and INPI2 NP application validly claims priority from INPI1 application.

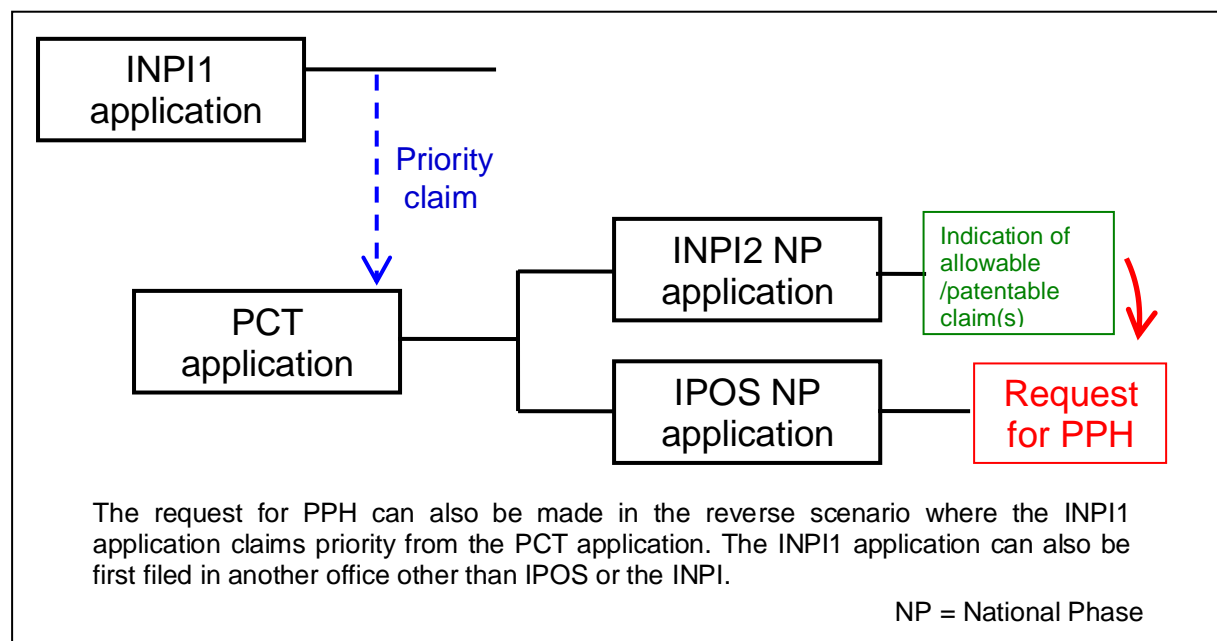

Scenario 9: There is a first PCT application. There is a second PCT application validly claiming priority from the first PCT application. The IPOS application is a national phase entry of the second PCT application, and the IPOS application validly claims priority under section 17 and section 87 of the Singapore Patents Act (Cap. 221) from the first PCT application. The INPI application being relied upon for the PPH request is a national phase entry of the second PCT application, and the INPI application validly claims priority under the Brazilian Patent law from the first PCT application.

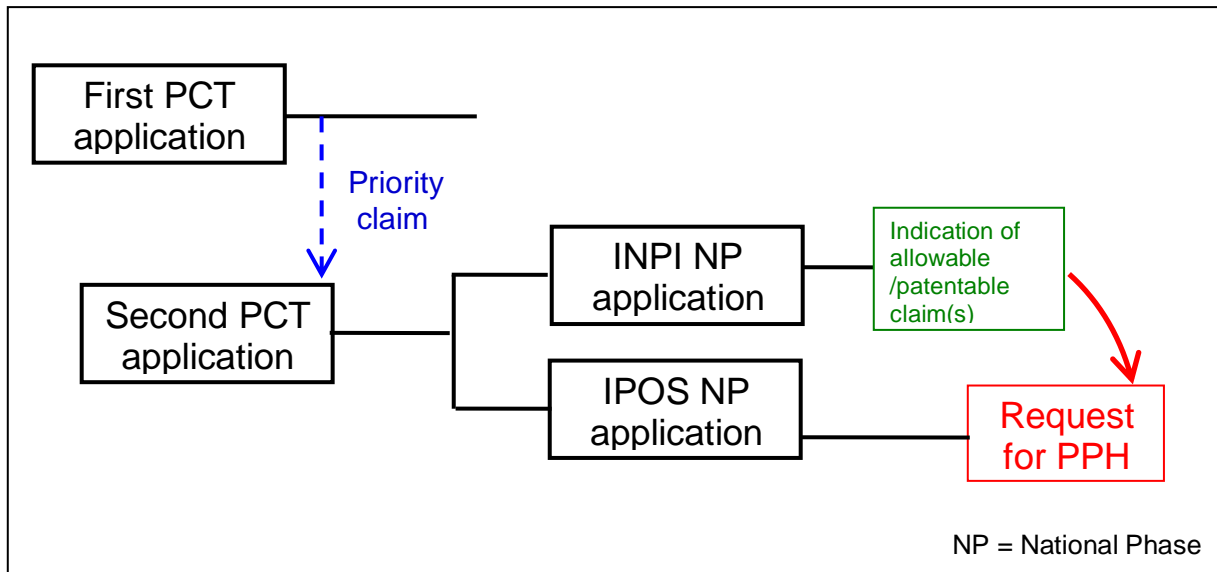

Scenario 10: There is a first PCT application. There is a second PCT application validly claiming priority from the first PCT application. The IPOS application ("IPOS NP application") is a national phase entry of the second PCT application. The INPI application ("INPI NP application") being relied upon for the PPH request is a national phase entry of the first PCT application.

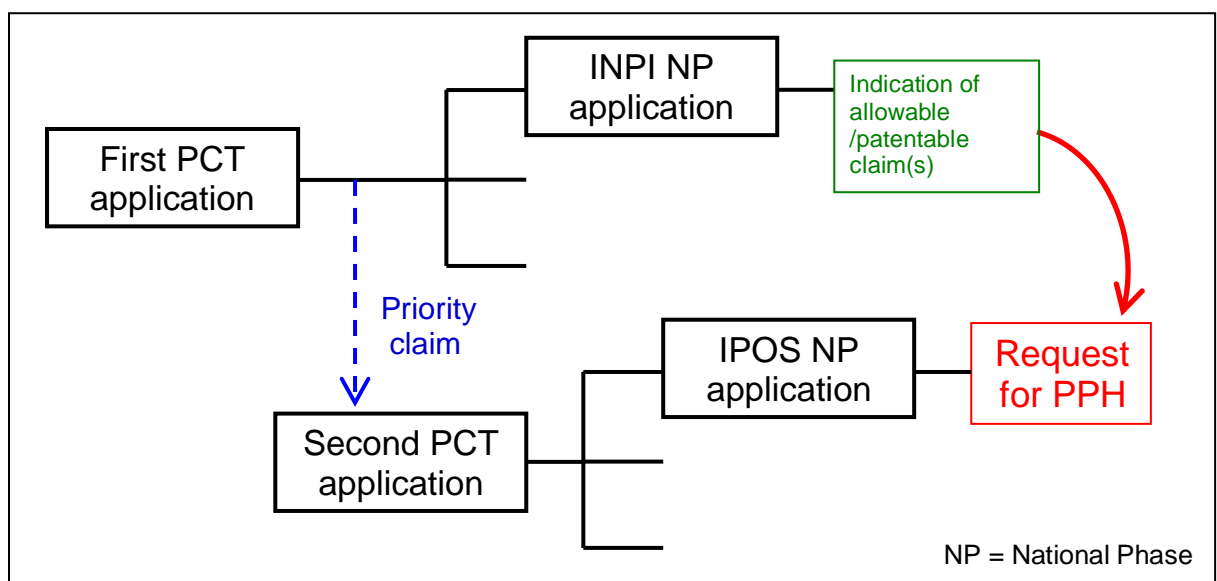

Scenario 11: The IPOS application (“IPOS NP application”) and the INPI application (“INPI NP application”) being relied upon for the PPH request, are national phase entries of the same PCT application.

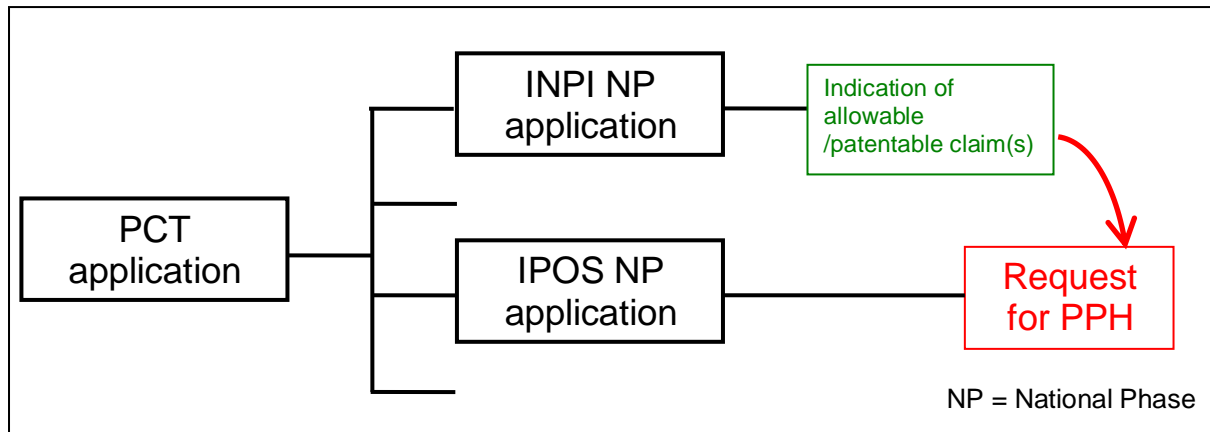

Scenarios using the PCT Work Product

Scenario (12): The IPOS application (“IPOS NP application”) is a national phase entry of the PCT application filed either at INPI as RO. The PCT application is being relied upon for the PPH request and it is examined by the INPI as International Authority (IA) (“INPI/IA application”).

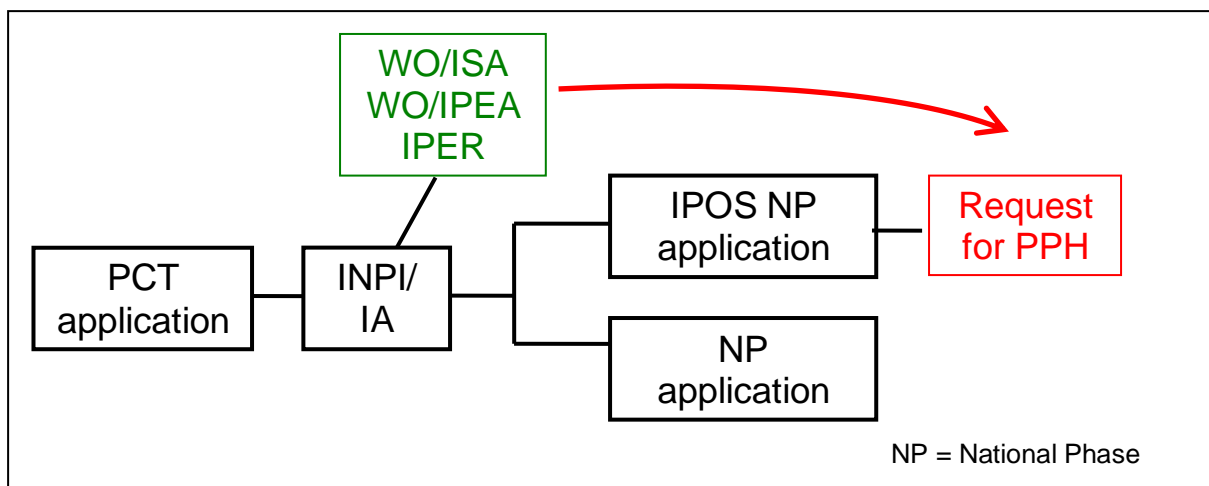

Scenario 13: There are two PCT applications, the second application validly claiming priority from the first application. The IPOS application is a national phase entry of the second PCT application (“IPOS NP application”). The second PCT Application is being relied upon for the PPH request and it is examined by INPI as International Authority (IA) (“INPI/IA application”).

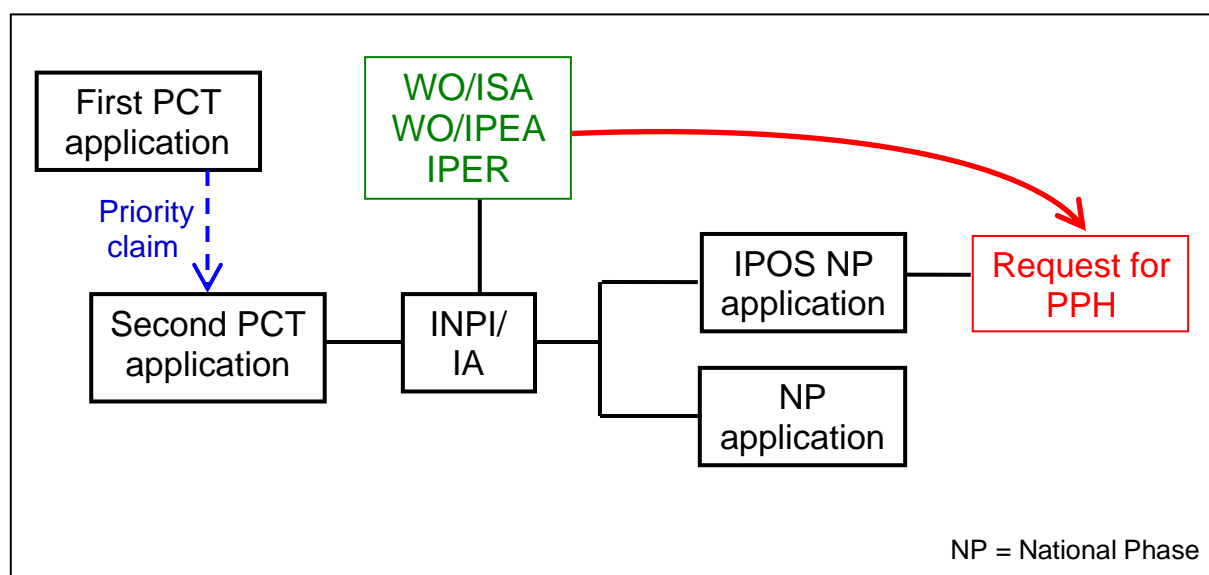

Scenario 14: There is a first application filed in an office other than the IPOS or the INPI. The PCT application validly claims priority from the first application. The IPOS application is a national phase entry of the PCT application (“IPOS NP application”). The PCT application is being relied upon for the PPH request and it is examined by the INPI as International Authority (IA) (“INPI/IA application”).

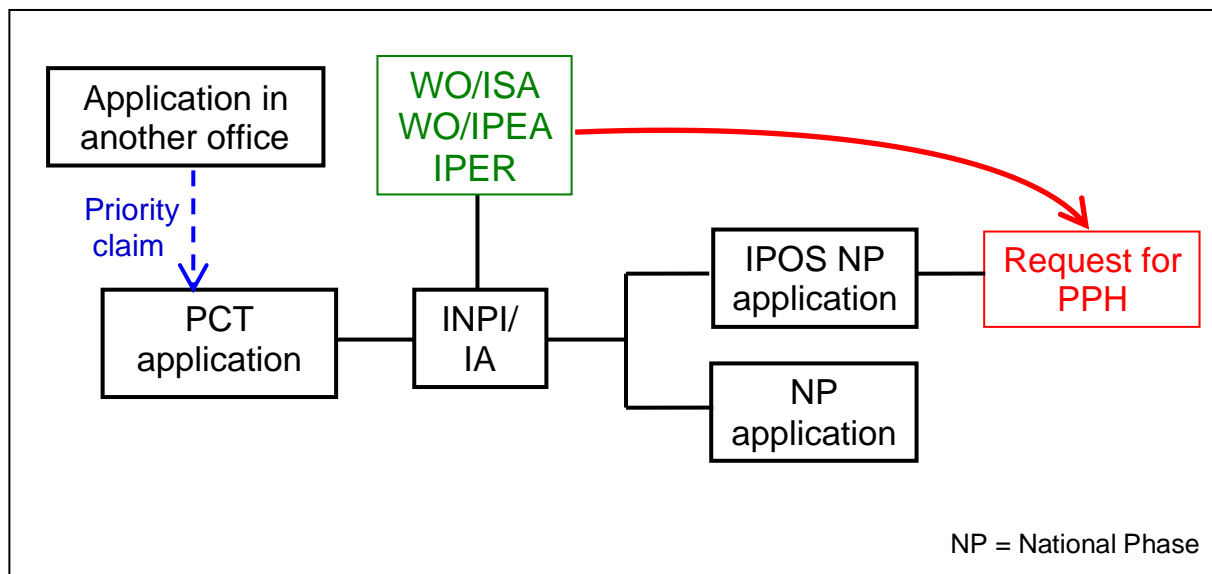

Scenario 15: The PCT application validly claims priority from an IPOS application. The PCT application is being relied upon for the PPH request for the IPOS application and it is examined by the INPI as International Authority (IA) (“INPI/IA application”).

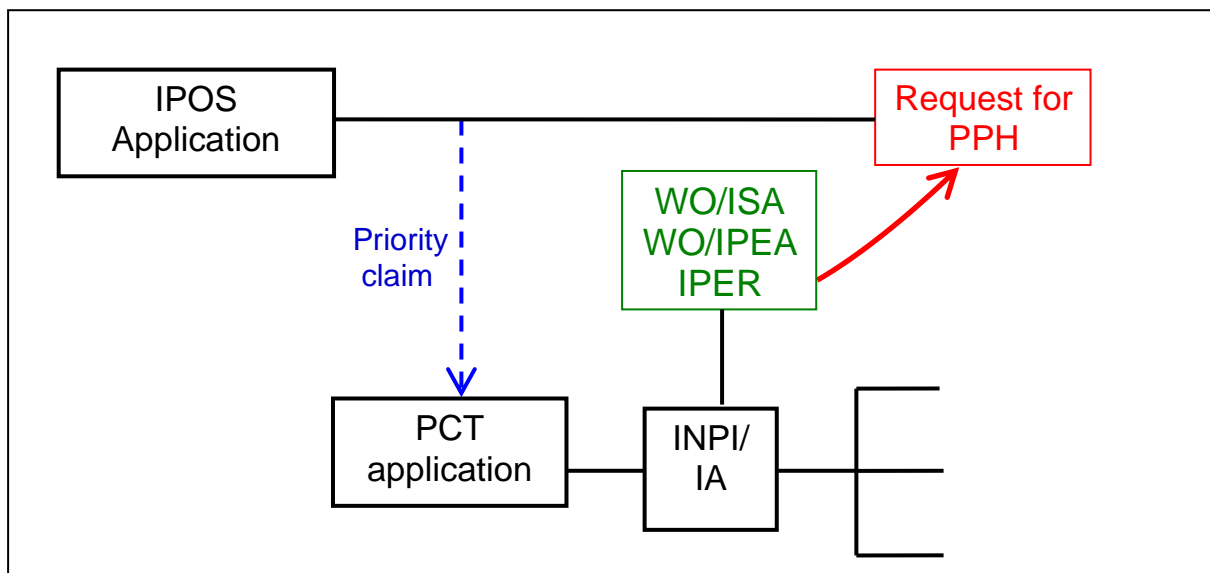

Scenario 16: There are two IPOS application. The PCT application validly claims priority from the first IPOS application (“IPOS 1 Application”). The second IPOS application (“IPOS 2 Application”) is a divisional application of the first IPOS application. The PCT application, examined by the INPI as International Authority (IA) (“INPI/IA application”), is being relied upon for the PPH request for the second IPOS application.

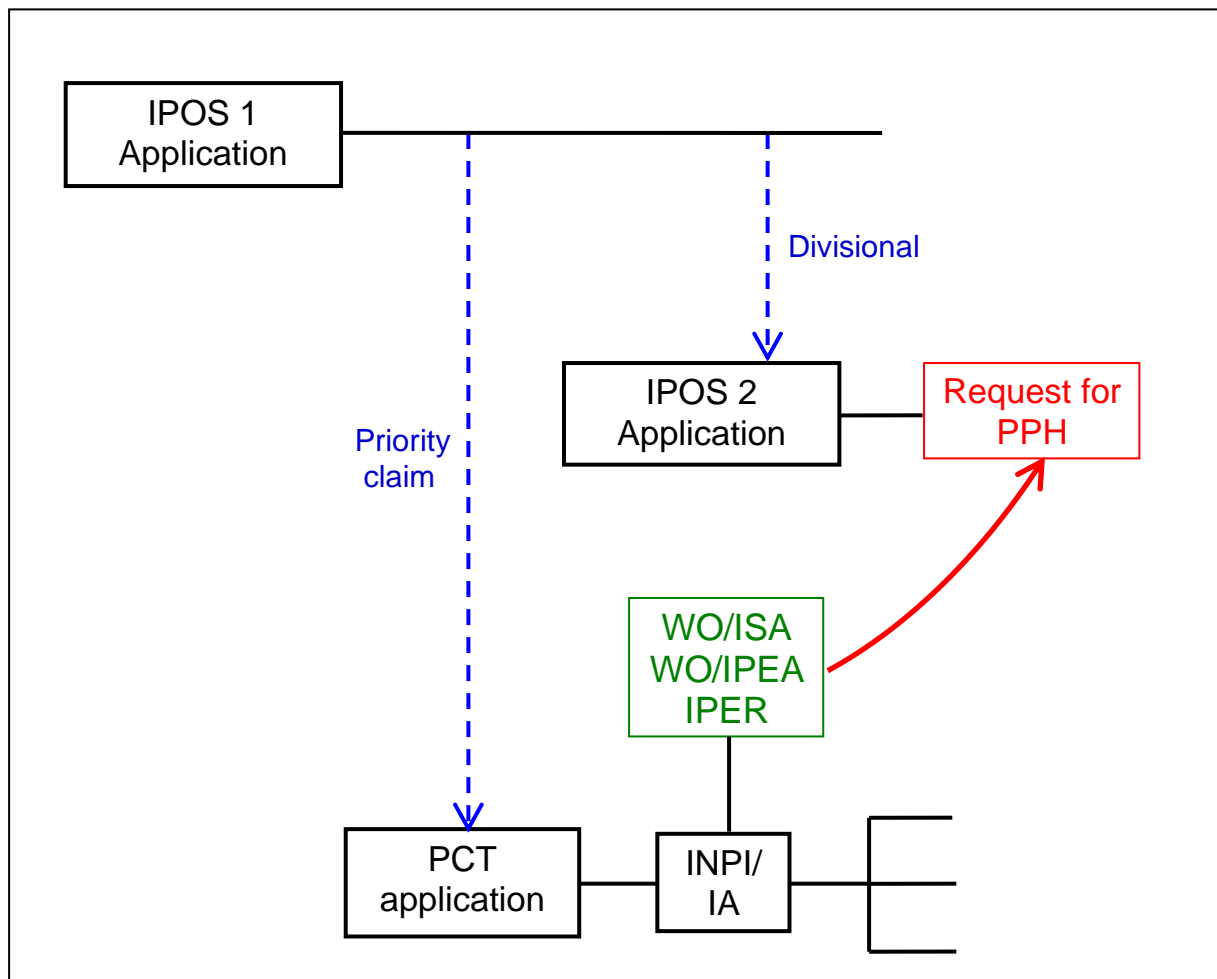

Scenario 17: There are two PCT applications, the second application validly claiming priority from the first application. The IPOS application is a national phase entry of the second PCT application (“IPOS NP application”). The first PCT application is being relied upon for the PPH request and it is examined by the INPI as International Authority (IA) (“INPI/IA application”).

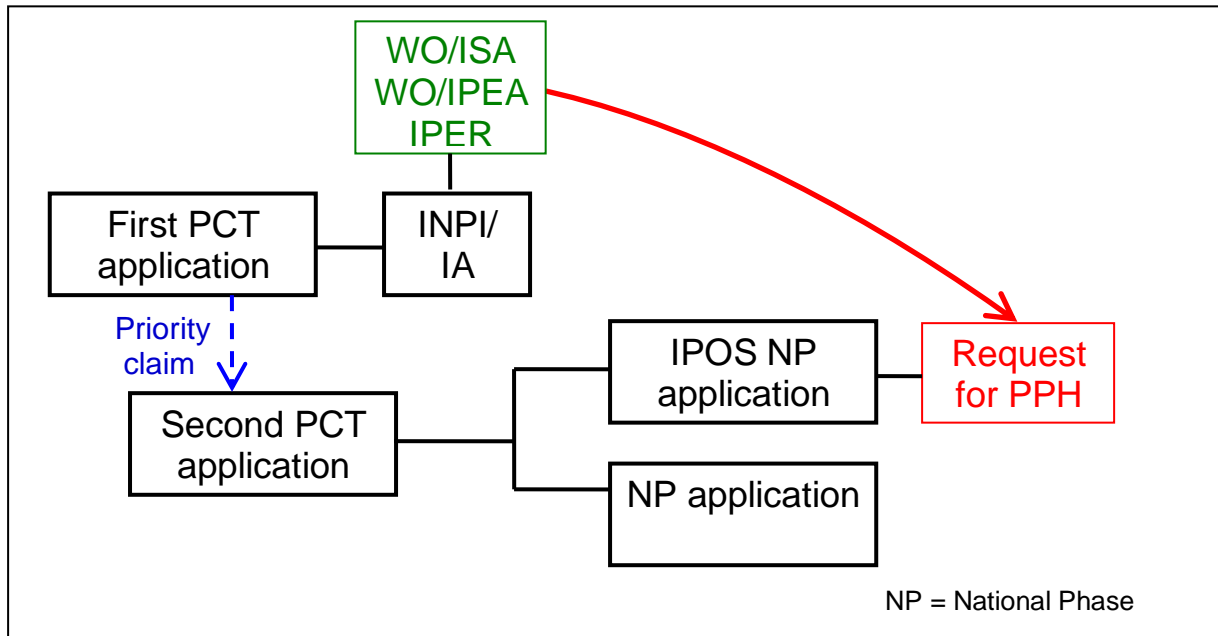

Scenario (18): The IPOS application is a divisional application of another IPOS application that is a national phase entry of a PCT application filed at INPI as RO. The PCT application is being relied upon for the PPH request and it is examined by the INPI as International Authority (IA) (“INPI/IA application”).

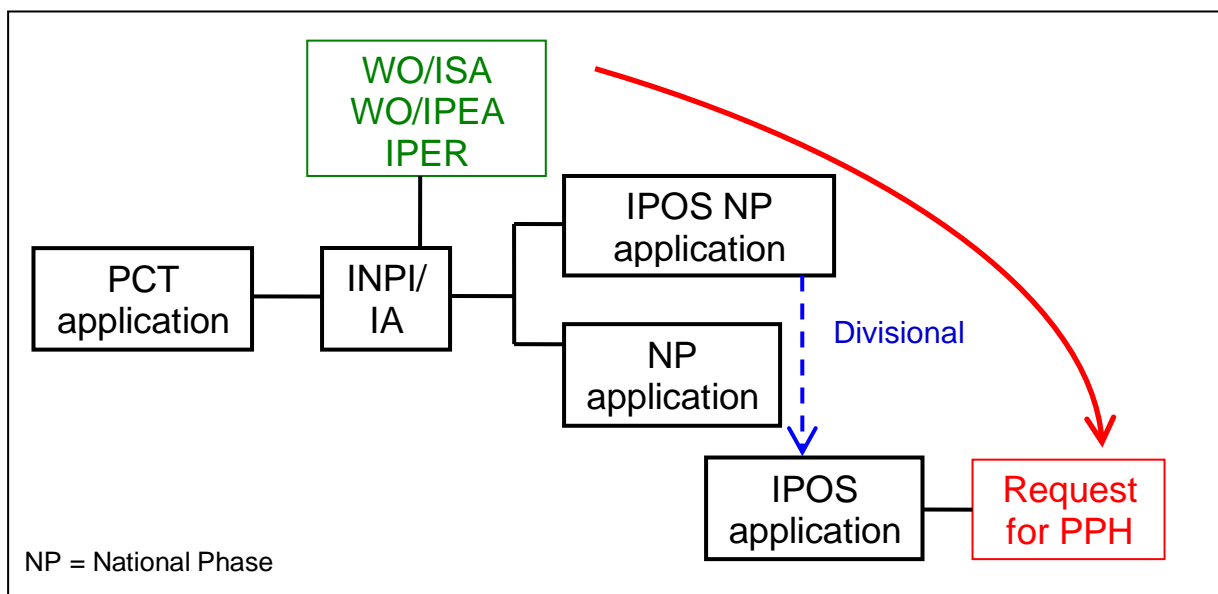

Scenario (19): The IPOS application (“IPOS2 application”) is a divisional application of another IPOS application (“IPOS1 application”). The PCT application validly claims priority from IPOS1 application. The PCT application is being relied upon for the PPH request and it is examined by the INPI as International Authority (IA) (“INPI/IA application”).

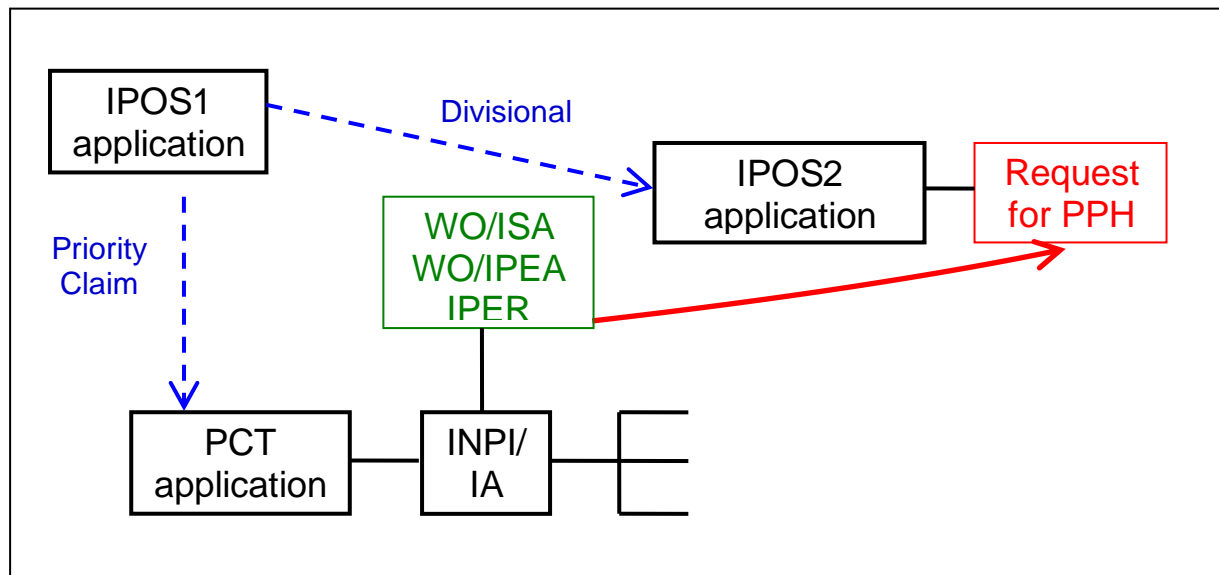

Annex II

Claim Correspondence Table (Patent Prosecution Highway)

OFFICE OF EARLIER EXAMINATION (OEE)	
OEE APPLICATION NUMBER	

CLAIMS IN IPOS APPLICATION³	EXAMINED CLAIMS IN OEE APPLICATION⁴	EXPLANATION REGARDING THE CORRESPONDENCE

Sheet/....

All the claims in the IPOS application sufficiently correspond to the patentable/allowable claims in the OEE application.

³ Please indicate the claim number relating to a claim in the current application which corresponds to the allowable/patentable claim in the OEE application.

⁴ Please indicate the claim number relating to a claim that has been determined to be allowable/patentable.