

Bilateral Patent Prosecution Highway Programme between the Intellectual Property Office of Singapore and the European Patent Office

1. Background

- 1.1 To obtain patent protection for an invention in several countries usually requires the invention to be searched and examined in each of the countries. If the patent authorities in these countries were to share the results of their search and/or examination with each other, the opportunity for a patent office to make reference to earlier work done could have several potential benefits:
- (a) Reduced work – Reference to the earlier work done could reduce or even eliminate the need for subsequent search and examination work.
 - (b) Accelerated examination – The reduced work could generally lead to a faster examination of the patent application.
 - (c) Better search and examination – Other patent offices might have access to databases unavailable (e.g. specific technical databases, local databases, databases in other languages) to the examiner, therefore the opportunity to refer to these search and examination results could provide the examiner with information on and assessment of prior art that he or she would otherwise not have access to.

2. Bilateral Patent Prosecution Highway Programme

- 2.1 The Bilateral Patent Prosecution Highway (PPH) Programme between the Intellectual Property Office of Singapore (IPOS) and the European Patent Office (EPO) is one way for the two offices to share their search and examination results with each other.
- 2.2 Where IPOS is the Office of Earlier Examination (OEE) and the IPOS application contains claims that are determined to be allowable/patentable, the applicant may request accelerated examination at the EPO for the corresponding application filed with the EPO as the Office of Later Examination (OLE). The requirements and procedures for filing a request with the EPO for participation in the PPH programme are available from the EPO website at: <http://www.epo.org/law-practice/legal-texts/official-journal/2017/12/a110.html>.
- 2.3 Where the EPO is the OEE and the EPO application contains claims that are determined to be allowable/patentable, the applicant may request accelerated examination of the corresponding application filed with IPOS as the OLE by furnishing certain information of the IPOS application as set out in the requirements and procedures below.

3. Bilateral PPH Programme

- 3.1 The Bilateral PPH Programme commences on January 6, 2015, for a period of 3 years, with a further extension of another 3 years thereafter until January 5, 2021.
- 3.2 In recognition of the benefits that the Bilateral PPH Programme brings to both regions and offices, the programme is extended in a permanent manner for an indefinite period of time with effect from 6 January 2021. IPOS and the EPO may terminate the programme if the volume of participation exceeds manageable level, or for any other reason. Notice will be published if the Bilateral PPH Programme will be terminated.

4. Requirements for requesting accelerated examination of an IPOS patent application under the PPH

- 4.1 Both the IPOS application for which acceleration is requested and the EPO application(s) forming the basis of the PPH request shall have the same earliest date (whether this is a priority date or a filing date).
- 4.2 The EPO application has at least one claim that is determined to be allowable/patentable by the EPO.
- 4.3 All claims in the IPOS application must sufficiently correspond or be amended to sufficiently correspond to one or more of the claims found allowable/patentable by the EPO. Claims will be considered to sufficiently correspond where, accounting for differences due to translations and claim format, the claims are of the same or similar scope, or the claims are narrower in scope. In this regard, a claim that is narrower in scope occurs when a claim in the IPOS application is amended to be further limited by an additional technical feature that is supported in the specification.
- 4.4 Examination has not begun on the IPOS application.
- 4.5 Diagrams depicting a list of scenarios in which a request for accelerated examination of the IPOS application can be made under the PPH programme are found in Annex I.

5. Procedures for requesting accelerated examination of an IPOS patent application under the PPH

- 5.1 File duly completed Patents Form 11 (Request for Search and Examination Report) or Patents Form 12 (Request for Examination Report). These forms can be found at: <https://digitalhub.ipos.gov.sg/> (electronic platform for online filing).
- 5.2 The Patents Form 11 or Patents Form 12 must be accompanied by:
 - (a) a copy of all office actions of the EPO application being relied upon;
 - (b) a copy of the allowable/patentable patent claims referred to in (a) above; and
 - (c) a claims correspondence table showing the relatedness of the allowable/patentable claims referred to in (a) above to the claims in the current IPOS application. The format of the Claims Correspondence Table is found in Annex II.
- 5.3 The documents listed in 5.2 (a) can be either the:
 - (a) national work product established during the processing of a national application or a Patent Cooperation Treaty (PCT) application that has entered the national phase before the EPO; or
 - (b) PCT work product established by the EPO as International Searching Authority or International Preliminary Examining Authority.
- 5.4 If the documents listed in 5.2(a) and 5.2(b) above are available in the EPO Dossier Access System or the World Intellectual Property Organisation's PATENTSCOPE system, they need not be filed with the Patents Form 11 or Patents Form 12. The EPO Dossier Access System is accessible via

<http://www.epo.org/searching/free/register.html>. The PATENTSCOPE system is accessible via <http://www.wipo.int/pctdb/en/index.jsp>.

- 5.5 For avoidance of doubt, a copy of the patent grant without the documents listed in (a), (b) and (c) above will not qualify for the PPH.
- 5.6 The checkbox for "ASPEC/PPH" must be selected in the Patents Form 11 or Patents Form 12.
- 5.7 If the request for PPH is sought after the Patents Form 11 or Patents Form 12 is filed, an email must also be sent to IPOS at PT_acceleration@ipos.gov.sg. The email must contain in its subject, the title "PPH acceleration requested" and should also inform whether any amendments are required to conform the Singapore claims to the foreign allowed claims. Upon receipt of the email, IPOS will advise if examination has started on the IPOS application, and if examination has not started, we will invite the applicant to submit the relevant PPH documents in 5.2 via ad-hoc correspondence at <https://digitalhub.ipos.gov.sg/>.
- 5.8 Any subsequent correspondences with IPOS must also be marked with the phrase "PPH acceleration requested".

6. Cited Documents

- 6.1 A copy of each of the documents cited in the documents submitted under paragraph 5.2 (a) is not required at the time of filing the PPH request. IPOS may, however, require the applicant to furnish a copy of any document cited subsequently.

7. Translations

- 7.1 The documents in paragraph 5.2 must be accompanied by an English translation if they are not originally in English, at the time of filing the PPH request.
- 7.2 The documents in paragraph 6 may be filed in their original language. However, IPOS may subsequently request for an English translation of a document or a part of a document if an English abstract of the cited document is not available.
- 7.3 If it is not possible for IPOS to understand the English translation of any document, IPOS can request the applicant to resubmit the English translation of that document.

8. PPH Request

- 8.1 IPOS will treat a PPH request as a request for accelerated examination under the PPH programme. Where the PPH request is granted, the IPOS application will be processed in an accelerated manner. In those instances, where the PPH request does not meet all the requirements and procedures set forth above, the applicant will be notified and the defects in the request will be identified. The applicant will be given one opportunity to correct formal deficiencies identified in the request. If the request is not corrected, the application will be taken out of the PPH programme and the applicant will be notified.

9. Examination of IPOS patent application under the PPH

- 9.1 The IPOS application will be examined in accordance with the Singapore Patents Act (Cap. 221) and the Singapore Patents Rules. The legislations can be found at: <https://www.ipos.gov.sg/resources/ip-legislation>.

9.2 Applicants should seek professional advice on patent matters in Singapore, in particular, with reference to section 30 (Grant of patent) and section 69 (Restrictions on relief for infringement) of the Singapore Patents Act (Cap. 221).

10. Enquiries

10.1 For enquiries relating to the Patent Prosecution Highway programme, please send an email to PT_acceleration@ipos.gov.sg.

INTELLECTUAL PROPERTY OFFICE OF SINGAPORE

DATE: 2 June 2022

Last updated: July 2023

Annex I

Scenarios using the National Work Product

Scenario (1): The IPOS application validly claims priority under section 17 of the Singapore Patents Act (Cap. 221) from the EPO application being relied upon for the PPH request.

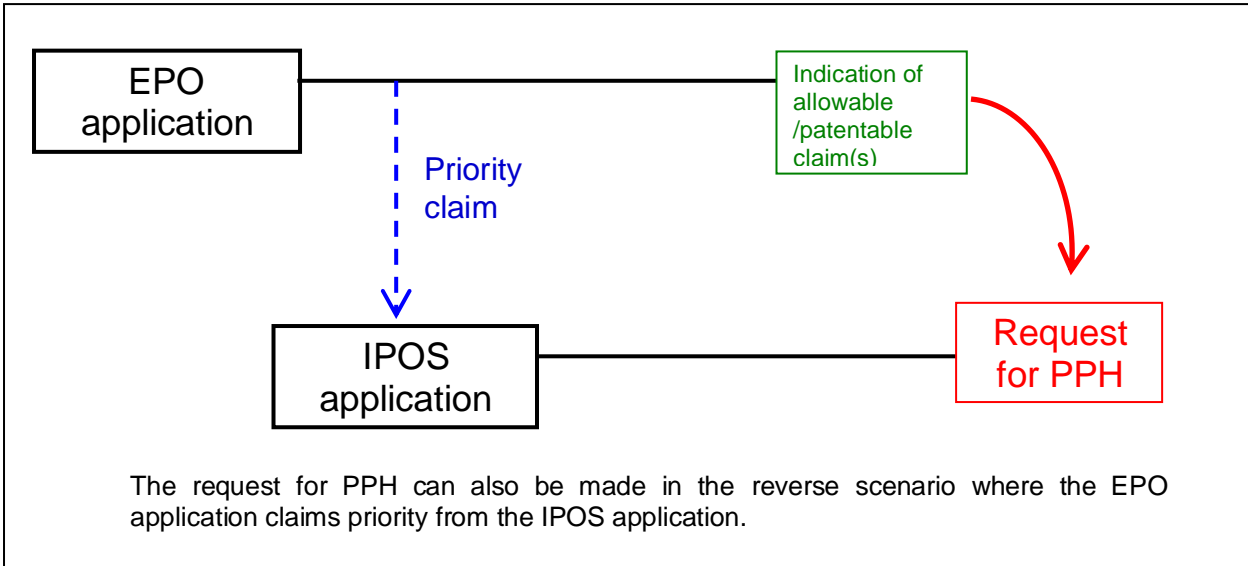

Scenario (2): The IPOS application is a divisional application of the IPOS application referred to in (1) above, and said divisional application validly claims priority under section 17 of the Singapore Patents Act (Cap. 221) from the EPO application being relied upon for the PPH request.

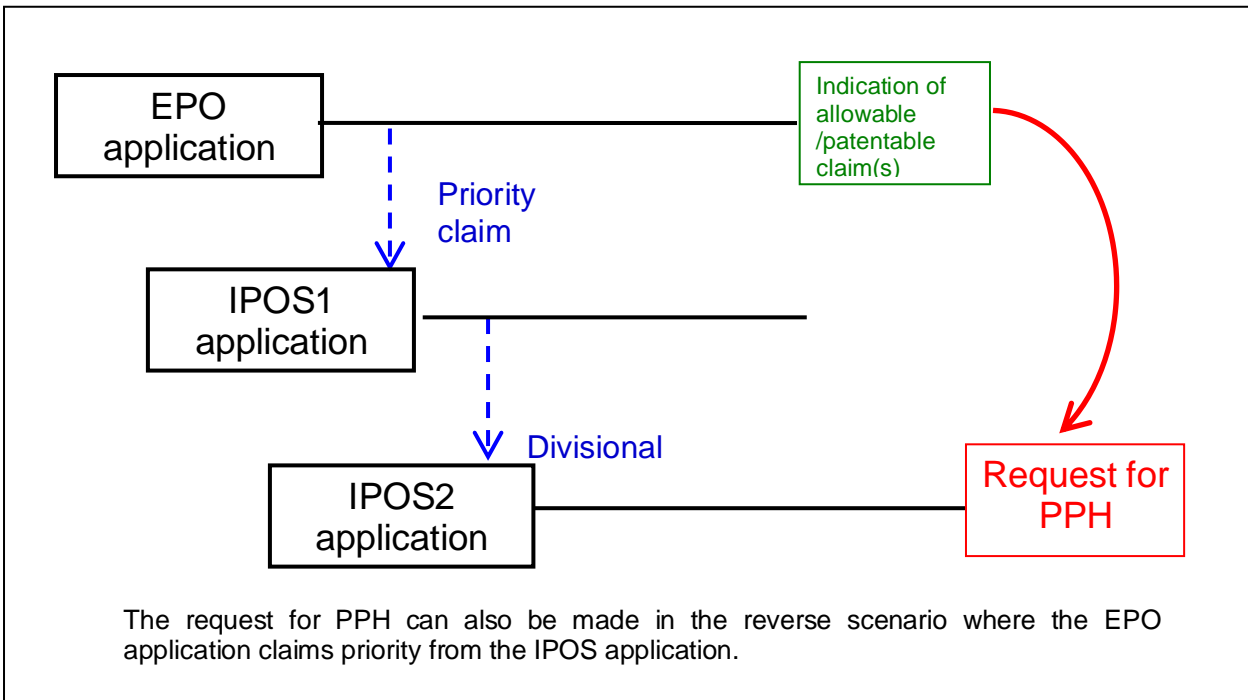

Scenario (3): The IPOS application validly claims priority under section 17 of the Singapore Patents Act (Cap. 221) from the EPO application (“EPO1 application”), and the EPO application being relied upon for the PPH request (“EPO2 application”) also validly claims domestic priority from EPO1 application.

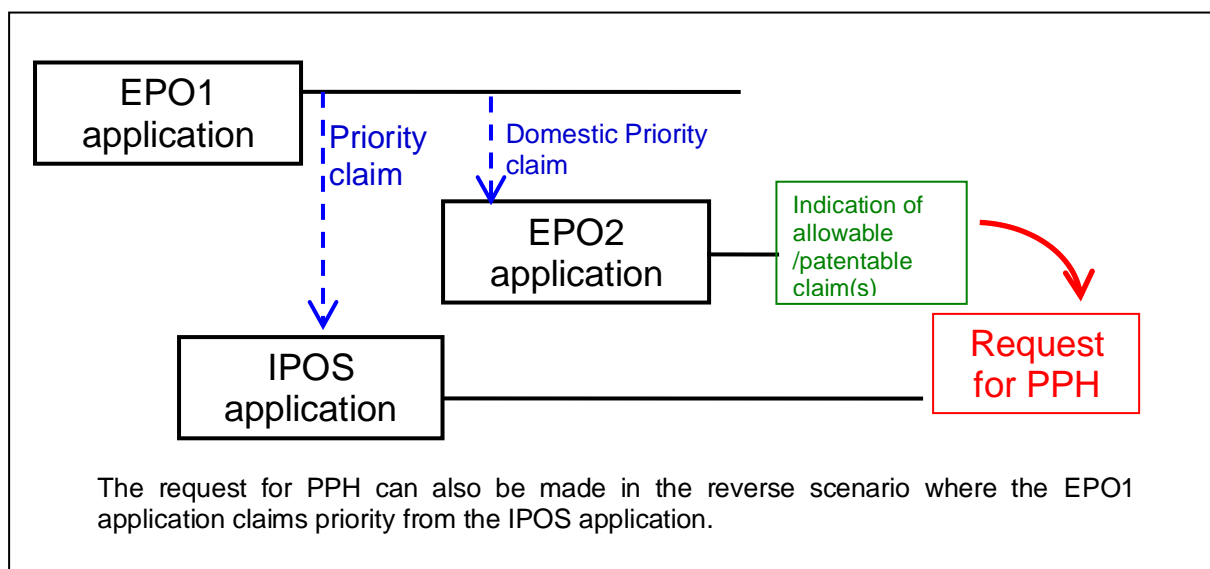

Scenario (4): The IPOS application is a divisional application of the IPOS application referred to in (3) above, and said divisional application validly claims priority under section 17 of the Singapore Patents Act (Cap. 221) from the EPO application (“EPO1 application”), and the EPO application being relied upon for the PPH request (“EPO2 application”) also validly claims domestic priority from EPO1 application.

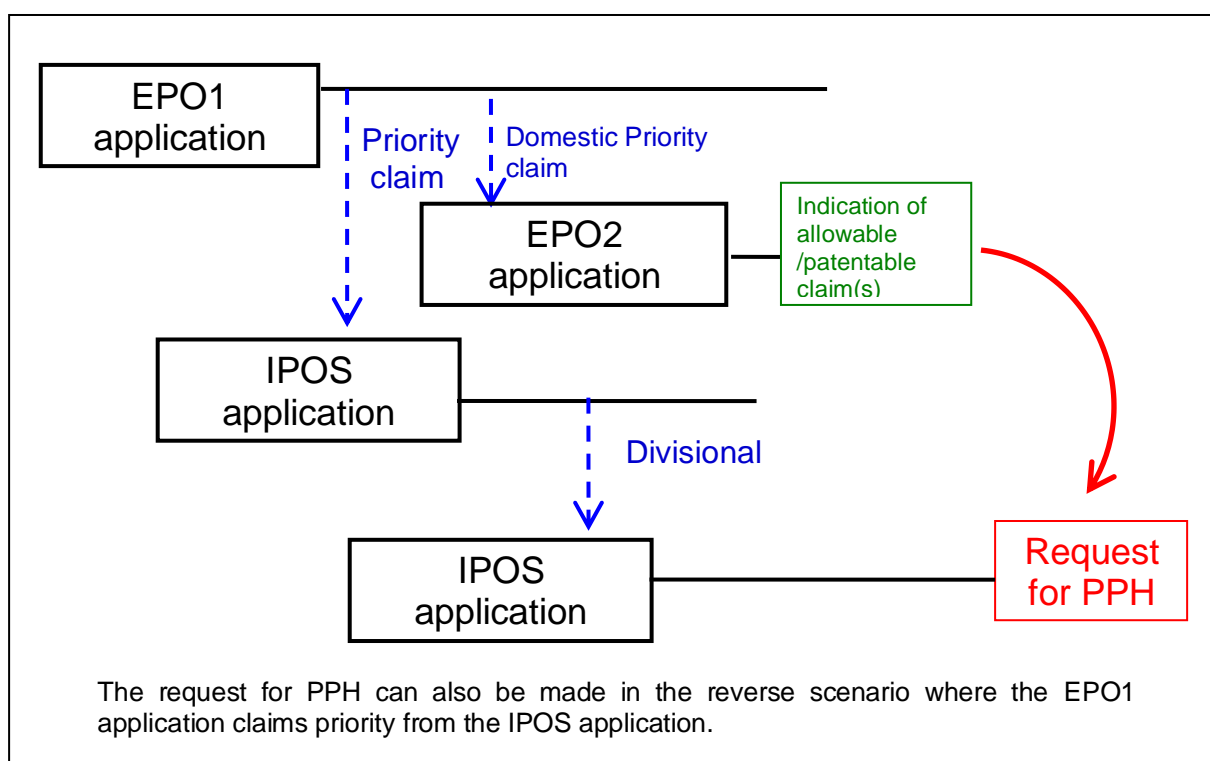

Scenario (5): The IPOS application is a national phase entry of a PCT application (“IPOS NP application”), and the IPOS application validly claims priority under section 17 and section 87 of the Singapore Patents Act (Cap. 221) from the EPO application. The EPO application is being relied on for the PPH request.

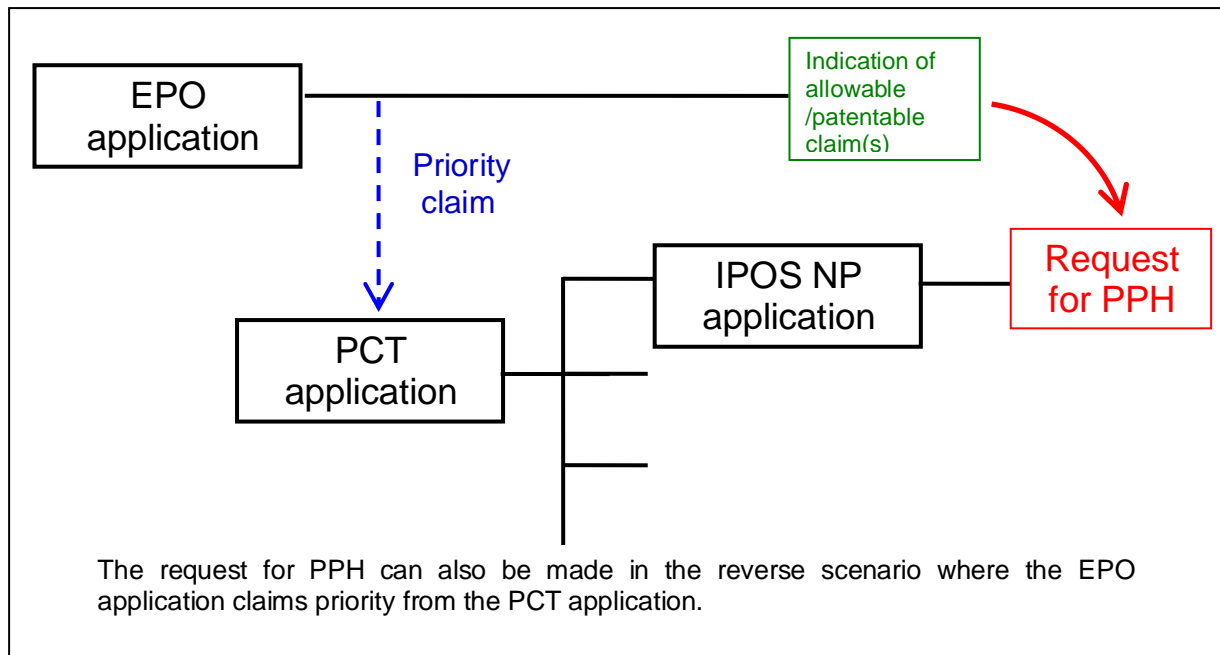

Scenario (6): The IPOS application is a national phase entry of a PCT application (“IPOS NP application”), and the IPOS application validly claims priority under section 17 and section 87 of the Singapore Patents Act (Cap. 221) from the EPO application (“EPO1 application”). The EPO application being relied upon for the PPH request (“EPO2 NP application”) is a national phase entry of the same PCT application, and EPO2 NP application validly claims priority from EPO1 application.

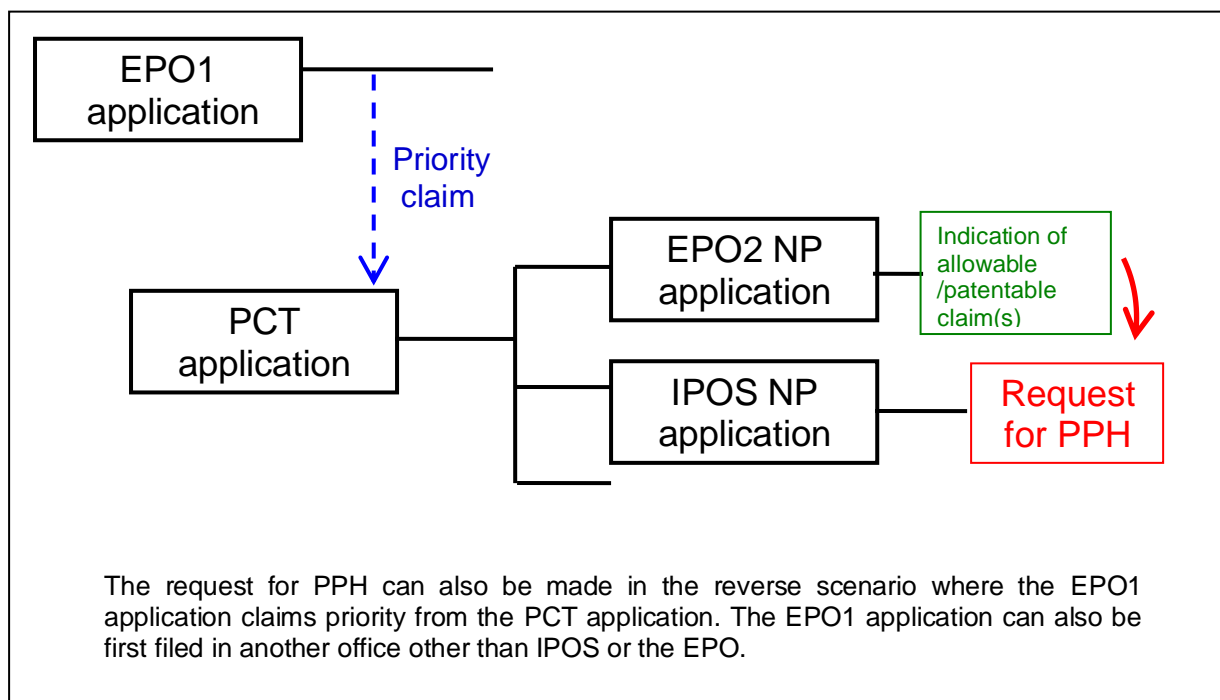

Scenario (7): There are two PCT applications, the second application validly claiming priority from the first application. The IPOS application (“IPOS NP application”) is a national phase entry of the second PCT application, and the IPOS NP application validly claims priority under section 17 and section 87 of the Singapore Patents Act (Cap. 221) from the first PCT application. The EPO application (“EPO NP application”) being relied upon for the PPH request is a national phase entry of the second PCT application, and the EPO NP application validly claims priority from the first PCT application.

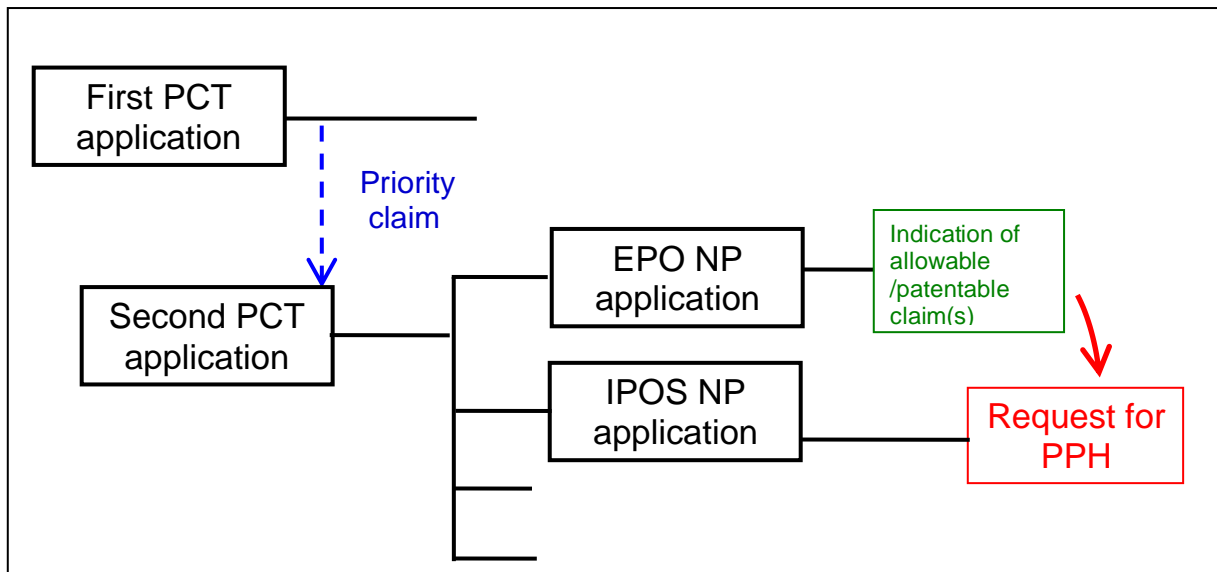

Scenario (8): There is a first application filed in an office other than the IPOS or the EPO. The IPOS application validly claims priority under section 17 of the Singapore Patents Act (Cap. 221) from the first application. The EPO application being relied upon for the PPH request also validly claims priority from the first application.

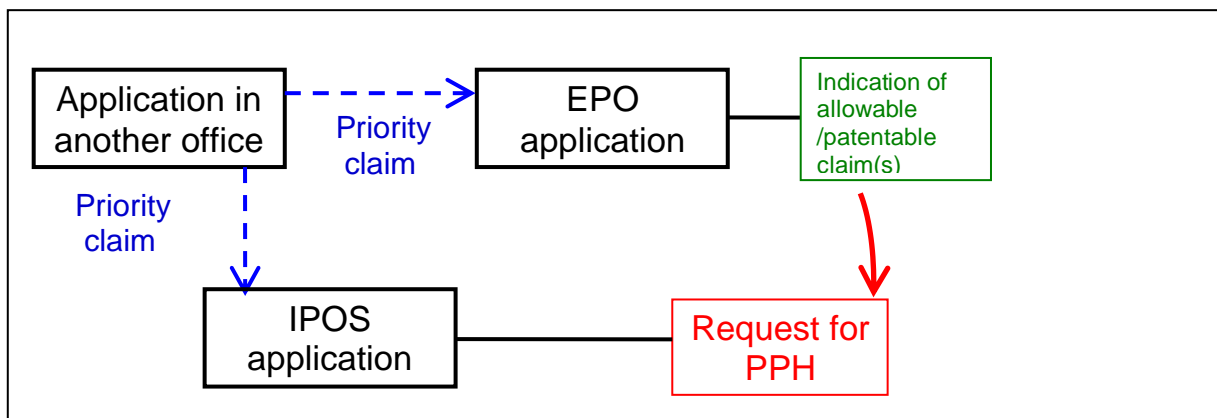

Scenario (9): The IPOS application (“IPOS NP application”) is a national phase entry of a PCT application, and the IPOS NP application validly claims priority under section 17 and section 87 of the Singapore Patents Act (Cap. 221) from an application filed in another office. The EPO application being relied upon for the PPH request also validly claims priority from the application filed in another office.

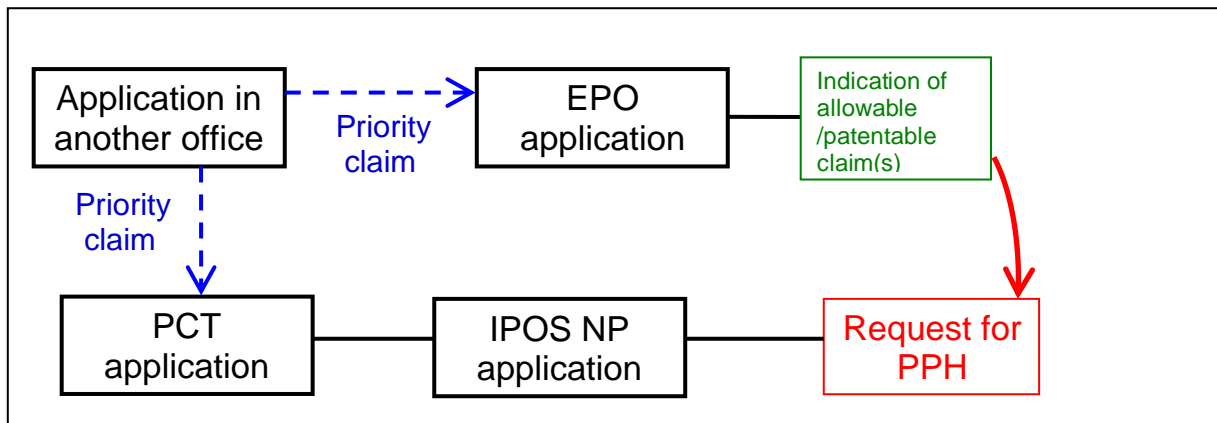

Scenario (10): The IPOS application (“IPOS NP application”) and the EPO application (“EPO NP application”) being relied upon for the PPH request, are national phase entries of the same PCT application

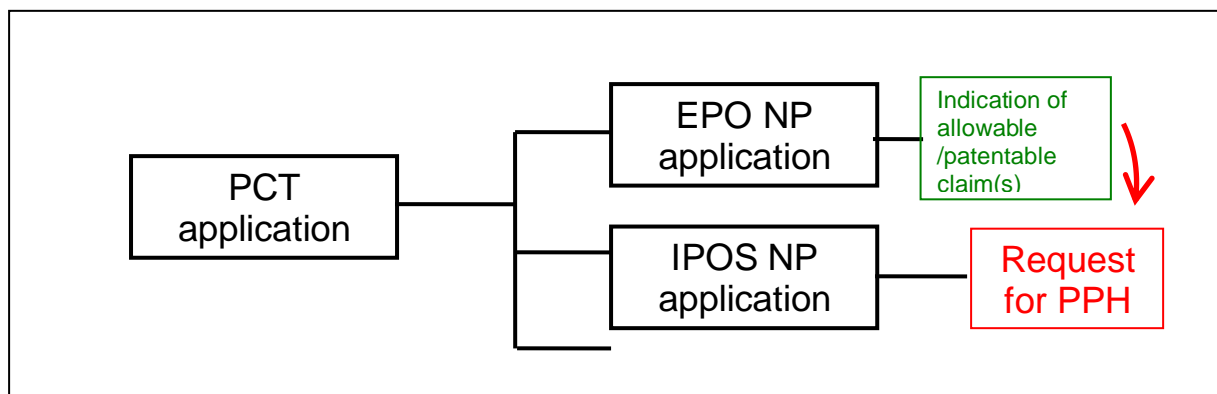

Scenarios using the PCT Work Product

Scenario (11): The IPOS application (“IPOS NP application”) is a national phase entry of the PCT application. The PCT application is being relied upon for the PPH request and it is examined by the EPO as International Authority (IA).

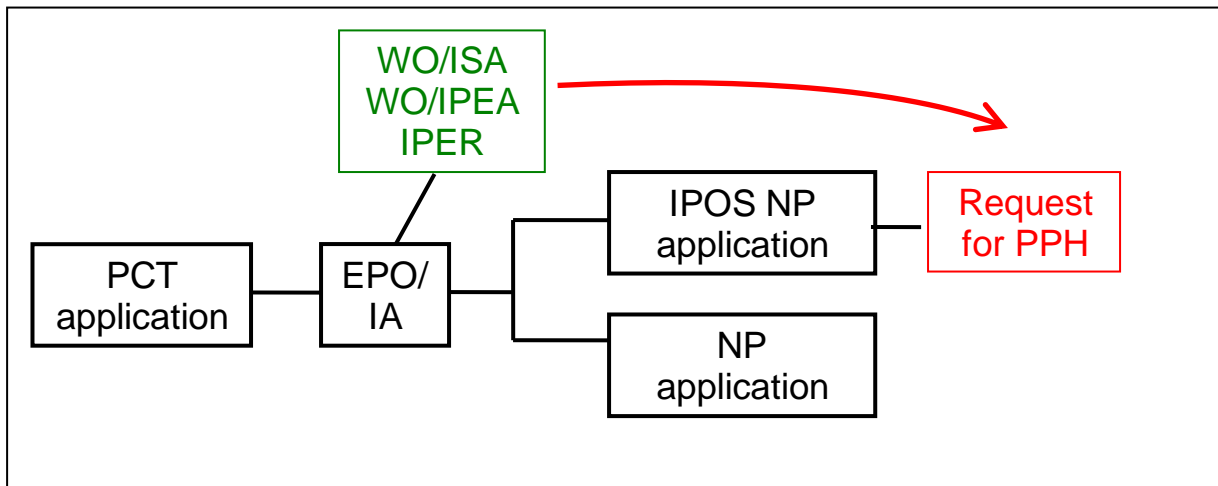

Scenario (12): There are two PCT applications, the second application validly claiming priority from the first application. The IPOS application (“IPOS NP application”) is a national phase entry of the second PCT application. The second PCT Application is being relied upon for the PPH request and it is examined by the EPO as International Authority (IA).

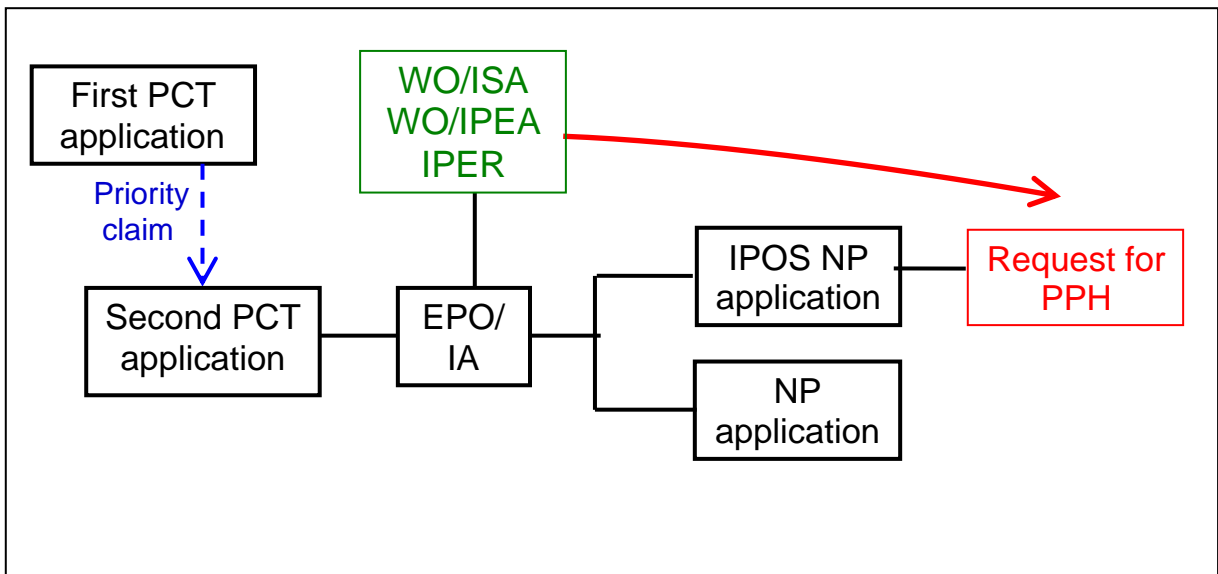

Scenario (13): There is a first application filed in an office other than the IPOS or the EPO. The PCT application validly claims priority from the first application. The IPOS application (“IPOS NP application”) is a national phase entry of the PCT application. The PCT application is being relied upon for the PPH request and it is examined by the EPO as International Authority (IA).

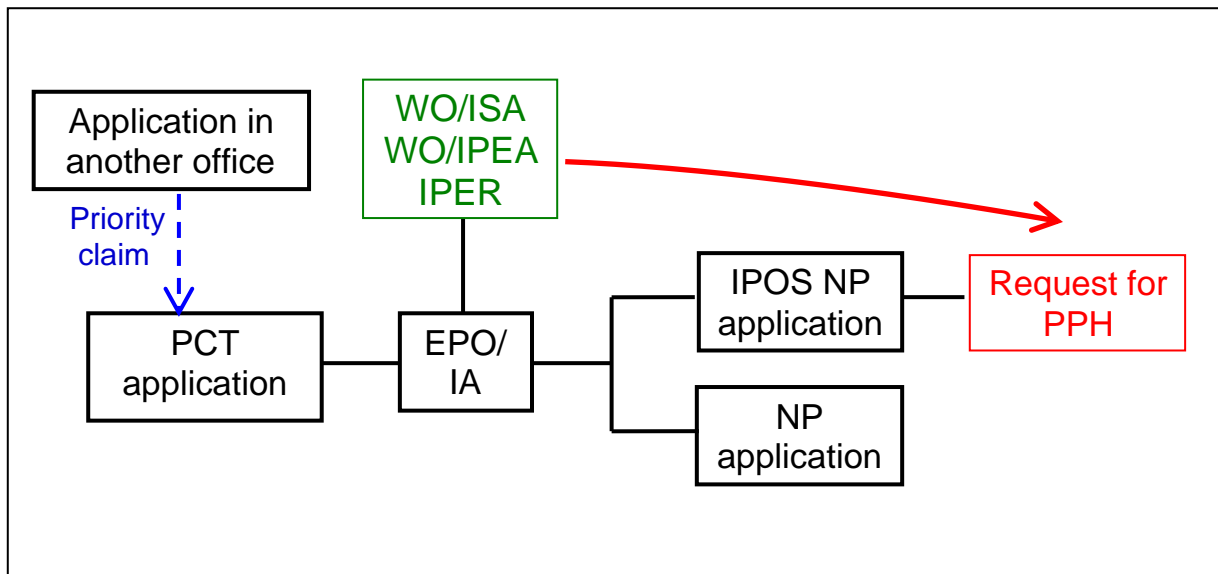

Scenario (14): The PCT application validly claims priority from the IPOS application. The PCT application is being relied upon for the PPH request and it is examined by the EPO as International Authority (IA).

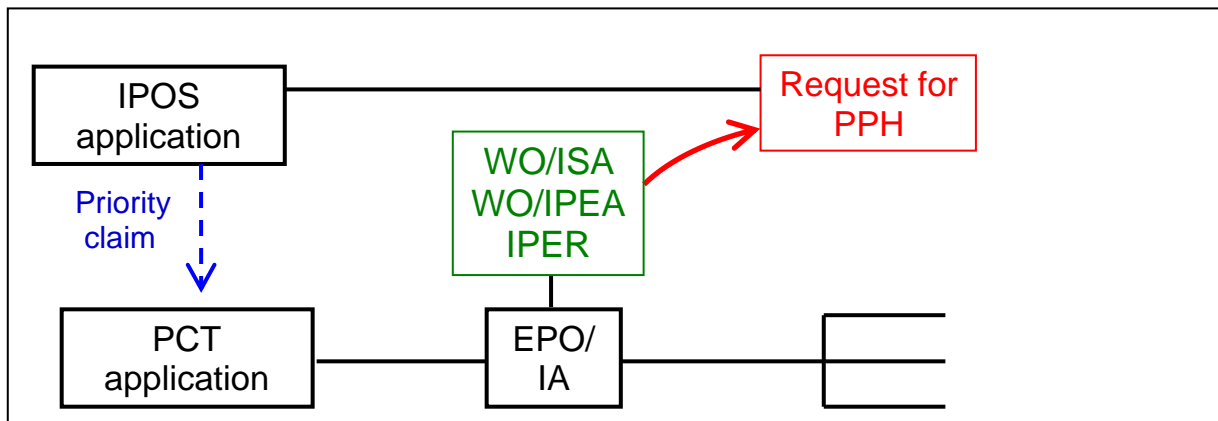

Scenario (15): There are two PCT applications, the second application validly claiming priority from the first application. The IPOS application (“IPOS NP application”) is a national phase entry of the second PCT application. The first PCT application is being relied upon for the PPH request and it is examined by the EPO as International Authority (IA).

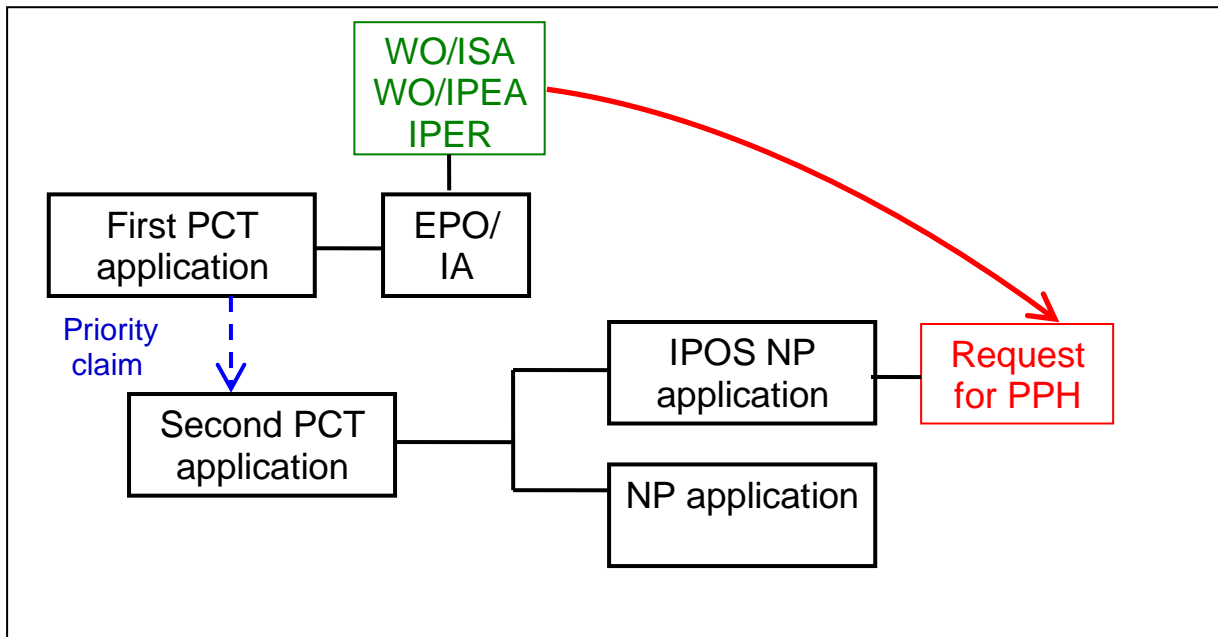

Scenario (16): The IPOS application validly claims priority under section 17 of the Singapore Patents Act (Cap. 221) from the PCT application. The PCT application is being relied upon for the PPH request and it is examined by the EPO as International Authority (IA).

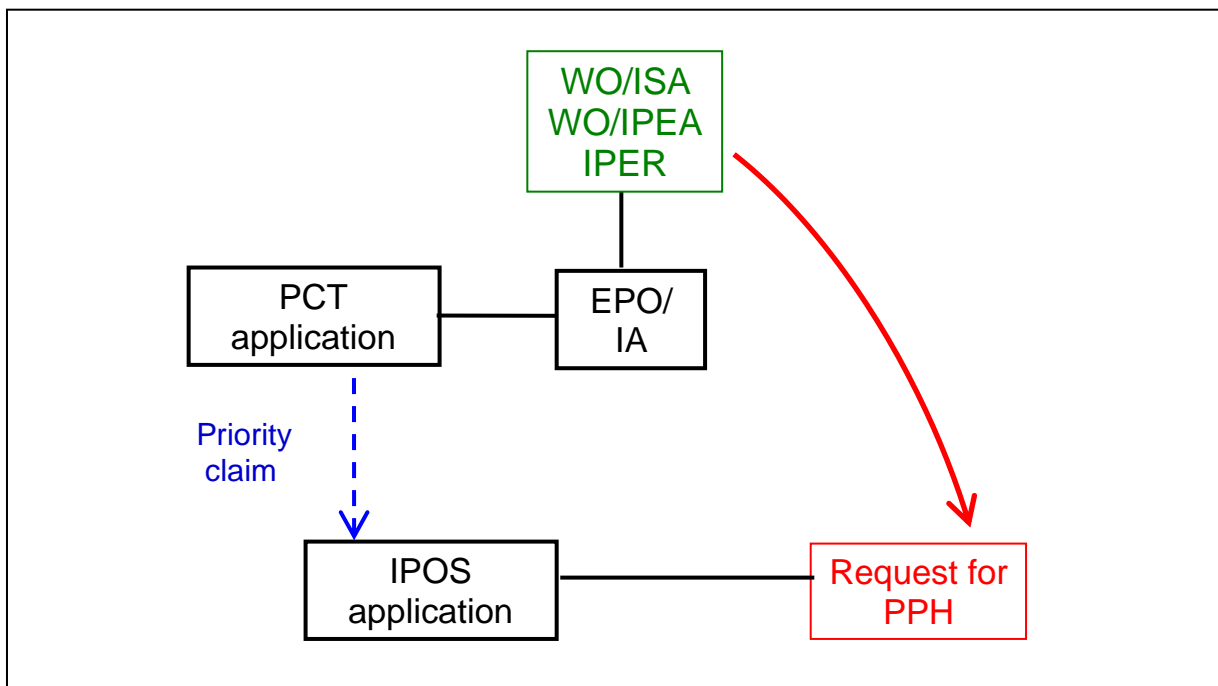

Scenario (17): The IPOS application is a divisional application of another IPOS application that is a national phase entry of a PCT application. The PCT application is being relied upon for the PPH request and it is examined by the EPO as International Authority (IA).

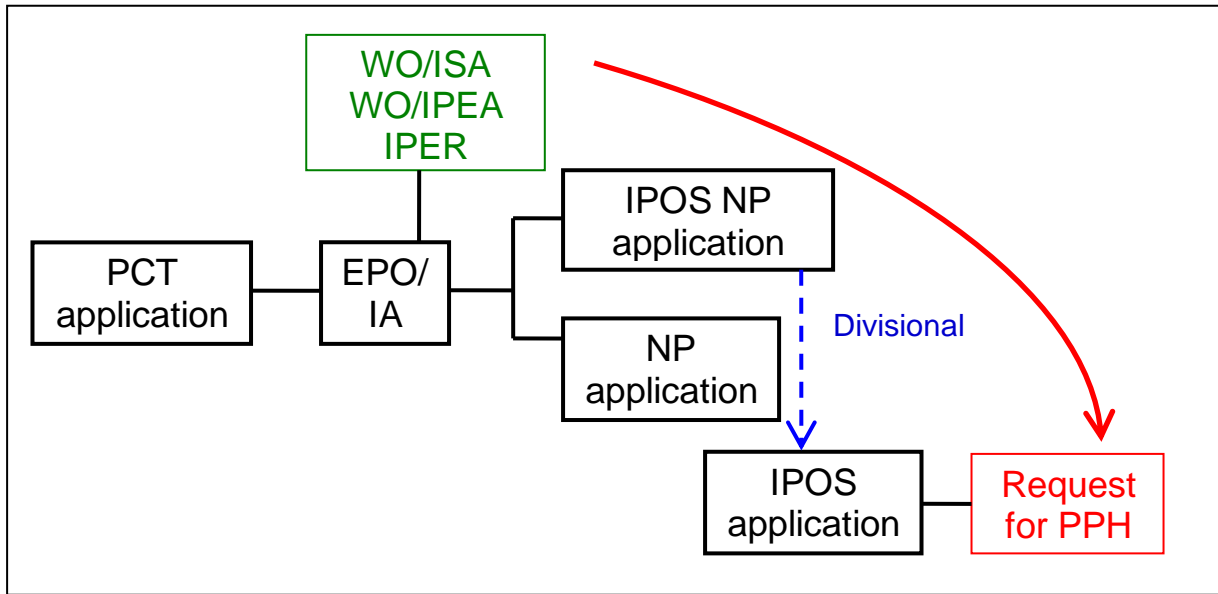

Scenario (18): The IPOS application (“IPOS2 application”) is a divisional application of another IPOS application (“IPOS1 application”). The PCT application validly claims priority from IPOS1 application. The PCT application is being relied upon for the PPH request and it is examined by the EPO as International Authority (IA).

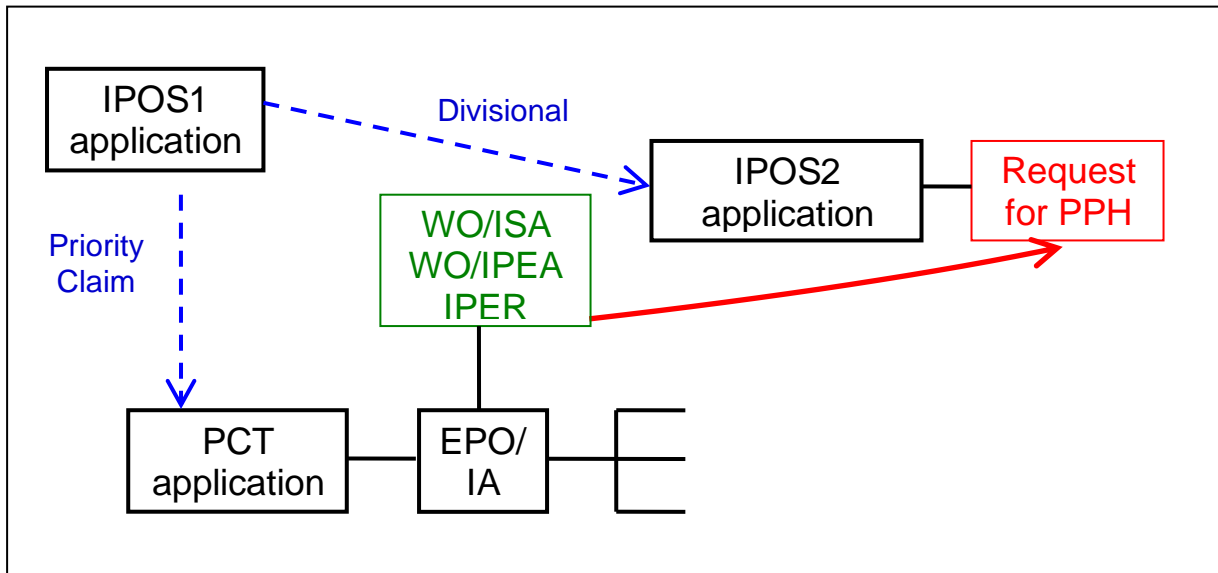

Note: The PCT work products are namely the Written Opinion of the International Search Authority (WO/ISA), the Written Opinion of the International Preliminary Examining Authority (WO/IPEA) or the International Preliminary Examination Report (IPER).

